

# **SATELLINE-EASy** **SATELLINE-EASy 869** **SATEL Compact-Proof** **Radio Modem**

## **User Guide**



## **IMPORTANT NOTICE**

All rights to this manual are owned solely by SATEL Oy (referred to in this user guide as SATEL). All rights reserved. The copying of this manual (without the written permission from the owner) by printing, copying, recording or by any other means, or the full or partial translation of the manual to any other language, including all programming languages, using any electrical, mechanical, magnetic, optical, manual or other methods or devices is forbidden.

SATEL reserves the right to change the technical specifications or functions of its products, or to discontinue the manufacture of any of its products or to discontinue the support of any of its products, without any written announcement and urges its customers to ensure, that the information at their disposal is valid.

SATEL software and programs are delivered "as is". The manufacturer does not grant any kind of warranty including guarantees on suitability and applicability to a certain application. Under no circumstances is the manufacturer or the developer of a program responsible for any possible damages caused by the use of a program. The names of the programs as well as all copyrights relating to the programs are the sole property of SATEL. Any transfer, licensing to a third party, leasing, renting, transportation, copying, editing, translating, modifying into another programming language or reverse engineering for any intent is forbidden without the written consent of SATEL.

SATEL PRODUCTS HAVE NOT BEEN DESIGNED, INTENDED NOR INSPECTED TO BE USED IN ANY LIFE SUPPORT RELATED DEVICE OR SYSTEM RELATED FUNCTION NOR AS A PART OF ANY OTHER CRITICAL SYSTEM AND ARE GRANTED NO FUNCTIONAL WARRANTY IF THEY ARE USED IN ANY OF THE APPLICATIONS MENTIONED.

Salo, FINLAND 2015

Copyright: 2015 SATEL Oy

No part of this document may be reproduced, transmitted or stored in a retrieval system in any form or by any means without the prior written permission of SATEL Oy. This document is provided in confidence and must not be distributed to third parties without the express permission of SATEL Oy.

## RESTRICTIONS ON USE

SATELLINE-EASy and SATEL Compact-Proof radio modems have been designed to operate on frequency ranges, the exact use of which differs from one region and/or country to another. The user of a radio modem must take care that the device is not operated without the permission of the local authorities on frequencies other than those specifically reserved and intended for use without a specific permit.

SATELLINE-EASy and SATEL Compact-Proof are allowed to be used in the following countries, either on licence free channels or on channels where the operation requires a licence. More detailed information is available at the local frequency management authority.

Countries: AT, AU, BE, BG, CA, CH, CY, CZ, DE, DK, EE, ES, FI, FR, GB, GR, HR, HU, IE, IS, IL, IN, IT, KZ, LT, LU, LV, MX, MT, NL, NO, OM, PL, PT, RU, RO, SE, SG, SI, SK, TR, UA, US, VN and ZA.

### WARNING!

Users of SATELLINE-EASy and SATEL Compact-Proof radio modems in North America should be aware, that due to the allocation of the frequency band 406.0 – 406.1 MHz for government use only, the use of radio modem on this frequency band without a proper permit is strictly forbidden.

### WARNING!

To be protected against all verified adverse effects the separation distance of at least 44 cm must be maintained between the antenna of this device and all persons. In addition to comply with FCC and IC RF exposure compliance requirements, maximum antenna gain is 14 dBi. The device must not be co-located or operating in conjunction with any other antenna or transmitter.

SATELLINE-EASy 869 and SATEL Compact-Proof radio modems have been designed to operate on 869.4125 – 869.6375 MHz, the exact use of which differs from one region and/or country to another. The user of a radio modem must take care that the device is not operated without the permission of the local authorities on frequencies other than those specifically reserved and intended for use without a specific permit.

SATELLINE-EASy 869 and SATEL Compact-Proof are allowed to be used in the following countries, either on licence free channels or on channels where the operation requires a licence. More detailed information is available at the local frequency management authority.

Countries: AT, BE, BG, CH, CY, CZ, DE, DK, EE, ES, FI, FR, GB, GR, HR, HU, IE, IS, IT, LT, LU, LV, MT, NL, NO, PL, PT, RO, SE, SI, SK and TR.

## PRODUCT CONFORMITY

Hereby, SATEL Oy declares that SATELLINE-EASy, -EASy 869 and SATEL Compact-Proof radio modems are in compliance with the essential requirements (radio performance, electromagnetic compatibility and electrical safety) and other relevant provisions of Directive 1999/5/EC. Therefore the equipment is labelled with CE-marking. The notification sign informs user that the operating frequency range of the device is not harmonised throughout the market area, and the local spectrum authority should be contacted before the usage of the radio modem.



### DECLARATION of CONFORMITY

*In Accordance with  
 1999/5/EC Directive*

*of the European Parliament and of the Council of 9 March 1999 on radio equipment and telecommunications terminal equipment and the mutual recognition of their conformity*

Doc No: SATEL-DC-RTTE-106  
 Manufacturer: SATEL Oy  
 Address: POB 142, (Meriniitynkatu 17), 24101 Salo, Finland

Products :	Type	Model
SATEL-TA13		SATELLINE-M3-TR1 SATELLINE-EASy SATEL Compact-Proof SATEL EASy-Proof

We, the manufacturer of the above-mentioned products, hereby declare that these products conform to the essential requirements of the European Union directive 1999/5/EC and 2011/65/EU. This Declaration of Conformity is based on the following documents:

Doc. No	Type of Product	Test Specification	Laboratory / Date of Issue
224551A	SATELLINE-M3-TR1	EN 300 113-2 V.1.5.1	NEMKO / Finland 10.1.2013
224551B	SATELLINE-M3-TR1	EN 300 113-2 V.1.5.1	NEMKO / Finland 10.1.2013
131691C	SATELLINE-M3-TR1	EN 301 489-1, -5	NEMKO / Finland 18.9.2009
131691D	SATELLINE-M3-TR1	EN 301 489-1, -5	NEMKO / Finland 31.8.2009
131691E	SATELLINE-M3-TR1	EN 60950-1:2006	NEMKO / Finland 30.9.2009
154710	SATELLINE-EASy	EN 301 489-1, -3	NEMKO / Finland 5.8.2010
154710	SATELLINE-EASy	EN 300 113-2 V.2.4.1	NEMKO / Finland 5.8.2010
173878	SATELLINE-EASy	EN 60950-1:2006	NEMKO / Finland 29.4.2011
277347-1-1	SATEL Compact-Proof	EN 300 113-1, -2	SGS Fimko / Finland 24.10.2014
277347-1-2	SATEL Compact-Proof	EN 301 489-1, -5	SGS Fimko / Finland 24.10.2014
277347-2	SATEL Compact-Proof	EN 60950-1:2006	SGS Fimko / Finland 7.11.2014

Salo on the 9<sup>th</sup> of January, 2015

SATEL Oy

  
 Kari Suominen  
 Vice President

  
 Aulis Törmä  
 Sales Director

SATEL Oy  
 PO Box 142, FI-24101 SALO, FINLAND  
 Street: Meriniitynkatu 17, FI-24100 SALO, FINLAND  
 Tel. +358 2 777 7800, Fax +358 2 777 7810  
 E-mail: info@satel.com, www.satel.com

  
 WIRELESS WORLD – LOCAL SOLUTION



## DECLARATION of CONFORMITY

### In Accordance with 1999/5/EC Directive

**of the European Parliament and of the Council of 9 March 1999 on radio equipment and telecommunications terminal equipment and the mutual recognition of their conformity**

Doc No: SATEL-DC-RTTE-107  
Manufacturer: SATEL Oy  
Address: POB 142, (Meriniitynkatu 17), 24101 Salo, Finland

Products :	Type	Model
	<b>SATEL-TA25</b>	<b>SATELLINE-M3-TR1 869</b> <b>SATELLINE-EASy 869</b> <b>SATEL Compact-Proof</b>

We, the manufacturer of the above-mentioned products, hereby declare that these products conform to the essential requirements of the European Union directive 1999/5/EC and 2011/65/EU. This Declaration of Conformity is based on the following documents:

Doc. No	Type of Product	Test Specification	Laboratory / Date of Issue
1-6042/13-01-02	M3-TR1 869	EN 300 220-1 V.2.4.1	CETECOM / DE 20.9.2013
1-6042/13-01-02	M3-TR1 869	EN 300 220-2 V.2.4.1	CETECOM / DE 20.9.2013
1-6042/13-01-03	M3-TR1 869	EN 301 489-1 V.1.9.2	CETECOM / DE 28.6.2013
1-6042/13-01-03	M3-TR1 869	EN 301 489-3 V.1.4.1	CETECOM / DE 28.6.2013
1-6042/13-01-04	M3-TR1 869	EN 60950-1:2006	CETECOM / DE 8.7.2013
247810	EASy 869	EN 300 220-2 V.2.4.1	NEMKO / FI 29.11.2013
247810	EASy 869	EN 301 489-1 V.1.9.2	NEMKO / FI 29.11.2013
247810	EASy 869	EN 301 489-3 V.1.6.1	NEMKO / FI 29.11.2013
278041-1	Compact-Proof	EN 301 489-3 V.1.6.1	SGS Fimko / FI 09.12.2014
278041-1	Compact-Proof	EN 301 489-1 V.1.9.2	SGS Fimko / FI 09.12.2014

Salo on the 9<sup>th</sup> of January, 2015

SATEL Oy



Kari Suominen  
Vice President



Aulis Törmä  
Sales Director

## **WARRANTY AND SAFETY INSTRUCTIONS**

Read these safety instructions carefully before using the product:

- Warranty will be void, if the product is used in any way that is in contradiction with the instructions given in this manual, or if the radio modem housing has been opened or tampered with.
- The radio modem is only to be operated at frequencies allocated by local authorities, and without exceeding the given maximum allowed output power ratings. SATEL and its distributors are not responsible, if any products manufactured by it are used in unlawful ways.
- The devices mentioned in this manual are to be used only according to the instructions described in this manual. Faultless and safe operation of the devices can be guaranteed only if the transport, storage, operation and handling of the devices is appropriate. This also applies to the maintenance of the products.
- To prevent damage both the radio modem and any terminal devices must always be switched OFF before connecting or disconnecting the serial connection cable. It should be ascertained that different devices used have the same ground potential. Before connecting any power cables the output voltage of the power supply should be checked.

### **NOTE!**

When selecting a suitable location for the radio modem it must be ensured that no water can get into the radio modem under any conditions. Direct sunlight is also to be avoided. It is not recommendable to install the radio modem on a strongly vibrating surface. Suitable dampening and/or isolation materials should be used in cases where the installation surface will be subjected to vibration.

## TABLE OF CONTENTS

<b>IMPORTANT NOTICE .....</b>	<b>2</b>
<b>RESTRICTIONS ON USE .....</b>	<b>3</b>
<b>PRODUCT CONFORMITY .....</b>	<b>4</b>
<b>WARRANTY AND SAFETY INSTRUCTIONS.....</b>	<b>6</b>
<b>TABLE OF CONTENTS .....</b>	<b>7</b>
<b>INTRODUCTION.....</b>	<b>11</b>
<b>1 SATELLINE-EASY TECHNICAL SPECIFICATIONS.....</b>	<b>12</b>
<b>2 SATELLINE-EASY 869 TECHNICAL SPECIFICATIONS.....</b>	<b>13</b>
<b>2.1 Important note for the users of SATELLINE-EASy 869 .....</b>	<b>14</b>
<b>3 SATEL COMPACT-PROOF TECHNICAL SPECIFICATIONS .....</b>	<b>15</b>
<b>3.1 Specification for battery.....</b>	<b>15</b>
<b>4 INTERFACE – CONNECTORS &amp; LEDS .....</b>	<b>16</b>
<b>4.1 Antenna connector.....</b>	<b>16</b>
<b>4.2 Power supply.....</b>	<b>16</b>
<b>4.3 Serial ports .....</b>	<b>17</b>
<b>4.4 LED indicators .....</b>	<b>17</b>
<b>4.5 LED indicator for charging .....</b>	<b>18</b>
<b>4.6 D15 connector SATELLINE-EASy and –EASy 869 .....</b>	<b>18</b>
<b>4.7 8-pin ODU and 4-pin ODU SATEL Compact-Proof .....</b>	<b>19</b>
<b>5 SERIAL INTERFACE.....</b>	<b>21</b>
<b>5.1 RS-232 interface (Port 1, Port 2) .....</b>	<b>22</b>
<b>5.2 RS-422 interface (Port 2).....</b>	<b>22</b>
<b>5.3 RS-485 interface (Port 2 externally connected).....</b>	<b>23</b>
<b>5.4 Termination of RS-422/485 lines .....</b>	<b>23</b>

<b>5.5</b>	<b>Serial data format .....</b>	<b>24</b>
<b>5.6</b>	<b>Handshaking lines.....</b>	<b>24</b>
5.6.1	CTS line .....	25
5.6.2	CD line .....	25
5.6.3	RTS line.....	25
5.6.4	DTR line .....	26
5.6.5	DSR line .....	26
<b>5.7</b>	<b>Pause length .....</b>	<b>26</b>
<b>5.8</b>	<b>Data buffering .....</b>	<b>27</b>
<b>6</b>	<b>RF INTERFACE.....</b>	<b>28</b>
<b>6.1</b>	<b>Transmitter .....</b>	<b>29</b>
<b>6.2</b>	<b>Receiver .....</b>	<b>30</b>
<b>6.3</b>	<b>Priority RX/TX.....</b>	<b>30</b>
<b>6.4</b>	<b>Forward Error Correction (FEC) .....</b>	<b>31</b>
<b>6.5</b>	<b>Error checking.....</b>	<b>31</b>
<b>6.6</b>	<b>TX delay .....</b>	<b>31</b>
<b>6.7</b>	<b>Separate RX/TX-frequencies.....</b>	<b>32</b>
<b>6.8</b>	<b>Free Channel Scan (FCS) .....</b>	<b>32</b>
<b>6.9</b>	<b>User data whitening .....</b>	<b>32</b>
<b>6.10</b>	<b>Pacific Crest and TRIMTALK compatibility .....</b>	<b>33</b>
6.10.1	Settings in compatibility modes.....	34
6.10.2	Repeater function.....	36
6.10.3	Support for Local / Remote addresses .....	36
6.10.4	Transmission delays .....	37
<b>7</b>	<b>TEST MODES.....</b>	<b>39</b>
<b>7.1</b>	<b>Short block test .....</b>	<b>39</b>
<b>7.2</b>	<b>Long block test.....</b>	<b>39</b>
<b>8</b>	<b>SETTINGS .....</b>	<b>40</b>
<b>9</b>	<b>SATEL CONFIGURATION MANAGER SOFTWARE .....</b>	<b>45</b>
<b>10</b>	<b>PROGRAMMING MODE MENU .....</b>	<b>46</b>
<b>10.1</b>	<b>Programming Mode.....</b>	<b>46</b>

<b>10.2</b>	<b>How to change the settings in the programming mode menu .....</b>	<b>47</b>
10.2.1	Example – How to change TX/RX frequencies .....	47
10.2.2	Restoring factory settings.....	48
10.2.3	Radio modem info .....	48
10.2.4	Activating tests.....	48
<b>11</b>	<b>LCD &amp; PUSH BUTTONS.....</b>	<b>49</b>
<b>11.1</b>	<b>LCD after power-up.....</b>	<b>49</b>
<b>11.2</b>	<b>Info pages.....</b>	<b>50</b>
<b>11.3</b>	<b>How to modify the settings on LCD .....</b>	<b>51</b>
11.3.1	Saving the modified settings .....	51
11.3.2	Example – how to change the radio frequency on LCD.....	52
11.3.3	Example – how to toggle settings ON or OFF on LCD .....	53
11.3.4	How to restore the factory settings on LCD.....	54
<b>12</b>	<b>SL COMMANDS .....</b>	<b>55</b>
<b>12.1</b>	<b>Changing parameters using the SL COMMANDS .....</b>	<b>55</b>
12.1.1	Addressing related SL commands .....	56
12.1.2	Channel list related SL commands .....	57
12.1.3	Serial port related SL commands .....	58
12.1.4	Memory related SL commands .....	58
12.1.5	Operation mode .....	58
12.1.6	Modem info related SL commands.....	59
12.1.7	Radio frequency related SL commands .....	60
12.1.8	Other SL commands .....	62
<b>13</b>	<b>CHANNEL LIST.....</b>	<b>63</b>
<b>14</b>	<b>REPEATER MODE AND ADDRESSING .....</b>	<b>64</b>
<b>14.1</b>	<b>Repeater .....</b>	<b>64</b>
<b>14.2</b>	<b>Addressing .....</b>	<b>65</b>
14.2.1	Connection between two points .....	67
14.2.2	System of one base station and several substations .....	67
<b>14.3</b>	<b>Using repeaters and addresses in the same system .....</b>	<b>68</b>
14.3.1	System with several repeaters .....	68
14.3.2	Repeater chain using address pairs .....	69
14.3.3	Repeater chain using dual addressing .....	70
14.3.4	Redundant repeater chain.....	70
<b>15</b>	<b>MESSAGE ROUTING .....</b>	<b>71</b>
<b>15.1</b>	<b>Introduction to Message Routing, .....</b>	<b>71</b>
15.1.1	Features of Message Routing .....	72
15.1.2	Limitations of Message Routing .....	72

15.1.3	Getting started with Message Routing.....	72
15.1.4	SaTerm and the configuration of the Message Routing .....	73
15.1.5	Manual configuration of the Message Routing.....	74
15.1.6	Configuration of the protocol in Message Routing .....	74
<b>15.2</b>	<b>Operating modes of Message Routing .....</b>	<b>75</b>
<b>15.3</b>	<b>Detailed description of Message Routing .....</b>	<b>76</b>
15.3.1	Source Mode Routing.....	76
15.3.2	Virtual Mode Routing .....	76
15.3.3	Overhop function in Source Mode Routing .....	76
15.3.4	Network ID .....	78
<b>16</b>	<b>INSTALLATION .....</b>	<b>79</b>
<b>16.1</b>	<b>Installation of the radio modem.....</b>	<b>79</b>
<b>16.2</b>	<b>Wiring .....</b>	<b>80</b>
16.2.1	RS-232 wiring - Port1 without handshaking.....	80
16.2.2	RS-232 wiring - Port1 and handshaking signals connected .....	81
16.2.3	RS-422 wiring .....	81
16.2.4	RS-485 wiring .....	82
16.2.5	Programming mode adapter .....	83
<b>16.3</b>	<b>Antenna installation .....</b>	<b>84</b>
16.3.1	Hand-held equipment .....	84
16.3.2	Mobile equipment.....	84
16.3.3	Base stations .....	84
16.3.4	General antenna installation instructions .....	84
<b>17</b>	<b>DESIGNING SYSTEMS.....</b>	<b>88</b>
<b>17.1</b>	<b>Factors affecting the quality and distance of the radio connection .....</b>	<b>88</b>
<b>17.2</b>	<b>Radio field strength .....</b>	<b>89</b>
<b>18</b>	<b>CHECK LIST.....</b>	<b>90</b>
<b>19</b>	<b>ACCESSORIES .....</b>	<b>91</b>
<b>20</b>	<b>APPENDIX A.....</b>	<b>92</b>
<b>21</b>	<b>APPENDIX B.....</b>	<b>93</b>
<b>21.1</b>	<b>Functional delays .....</b>	<b>93</b>
<b>21.2</b>	<b>Transmission delays.....</b>	<b>93</b>

## INTRODUCTION

SATEL Oy is a Finnish electronics and telecommunications company specialising in the design and manufacture of wireless data communication products. SATEL designs, manufactures and sells radio modems intended for use in applications ranging from data transfer to alarm relay systems. End users of SATEL products include both public organisations and private individuals.

SATEL Oy is the leading European manufacturer of radio modems. SATEL radio modems have been certified in most European countries and also in many non-European countries.

SATELLINE-EASy and SATEL Compact-Proof are a versatile transceiver radio modems that provides a compact and flexible solution for many different wireless applications. The key features include:

- 403-473 MHz frequency range – 70 MHz wide tuning range enables one radio modem in the stock and all the channels available
- User selectable channel spacing 12.5 / 20 / 25 kHz
- Compatible with the widely used SATELLINE-3AS radio modem family
- Compatible also with Pacific Crest-4FSK/GMSK/FST or TRIMTALK450s protocols
- Half duplex radio data transfer
- Over-the-air data rate:
  - 9600 bps @ 12.5 kHz channel spacing
  - 9600 bps @ 20 kHz channel spacing
  - 19200 bps @ 25 kHz channel spacing
- Small current consumption, sleep modes
- Power level of the transmitter 100 mW... 1 W
- RS-232 / RS422 / LVTTTL / TTL serial interface at 300...38400 bps data rates (SATEL Compact-Proof is only available with RS-232)
- LCD display and 4 push buttons (models with display)
  - Easy configuration, no need to use external terminal to change the basic settings
  - Monitoring of the signal (RSSI) or noise level and the voltage of the power supply
  - LCD is a useful tool in testing the radio connection
- LED indicators show the status of the interface signals.
- Routing/repeater functions
- Error correction (FEC)
- External command language (SL commands)
- SATEL Compact-Proof is in an IP67 classified housing
- SATEL Compact-Proof is available also in a IP67 classified housing with a battery

SATELLINE-EASy 869 and SATEL Compact-Proof are a frequency band variants targeted especially to the license free 869.4125...869.6375 MHz band in Europe.

SATEL Configuration Manager is the recommended PC software for configuring SATELLINE-EASy, -EASy 869 and SATEL Compact-Proof radio modems, although basic settings can be modified by using almost any terminal program. Alternatively, SATERM PC software can be used – it is the tool for designing and configuring the systems that utilize the Message routing features.

# 1 SATELLINE-EASy TECHNICAL SPECIFICATIONS

RADIO	RECEIVER	TRANSMITTER
Frequency Range	403...473 MHz (Tuning range 70 MHz)	
Channel Spacing	12.5 kHz / 20 kHz / 25 kHz programmable	
Communication Mode	Half-Duplex	
Frequency Stability	<1 kHz	
Modulation	4-FSK, GMSK	
Radio Compatibility	SATELLINE-3AS, Pacific Crest FST/4-FSK/GMSK, TRIMTALK450s	
Spurious Radiation	< 2 nW	EN 300 113 and CFR47 part90
Sensitivity	-114 dBm @12.5 kHz -111 dBm @25 kHz Note*) **)	
Co-channel Rejection	> -12 dB Note*)	
Adjacent Channel Selectivity	> 47 dB @12.5 kHz > 52 dB @ 25 kHz Note*)	
Intermodulation Attenuation	> 60 dB Note*)	
Blocking	> 86 dB Note*)	
Spurious Rejection	> 60 dB Note*)	
Spurious Emission	< -100 dBm	<-80 dBm on 3rd harmonic @1215–1240 MHz
Type of Emission		F1D
Carrier power		100, 200, 500, 1000 mW
Adjacent Channel Power		EN 300 113 and CRF47 part90
Carrier power stability		< ±1.5 dB
<b>DATA MODEM</b>		
Electrical Interface	Port 1:RS-232 / Port 2: LVTTTL, TTL or RS-232/422 (depends on the assembly)	
Interface Connector	D-15 (female)	
Data speed of Serial interface	300 – 38400 bps	
Data speed of Radio Interface	19200 bps (25 kHz channel) / 9600 bps (12.5 or 20 kHz channel)	
<b>GENERAL</b>		
Operating voltages	+6 ...+30 VDC or +3 ...+9 VDC (depending on the assembly)	
Power Consumption	<1.2 W (Receive), <3.0 W (Transmit @ 0.5 W), <7.0 W (Transmit @ 1 W), 0.12 W (Sleep mode), 10 mW (DTR Power save)	
Temperature Ranges	-25 °C ... +55 °C Complies with standards -30 °C ... +65 °C Functional -40 °C ... +75 °C Absolute min./max. -40 °C ... +85 °C Storage	
Antenna Connector	TNC female 50 ohm	
Construction	Aluminium housing	
Size L x W x T	139 mm x 67 mm x 29 mm	
Weight	250 g	
<b>COMPLIANT WITH THE INTERNATIONAL STANDARDS</b>		
RF-requirements	EN 300 113-2 / FCC CFR47 section 90	
EMC-requirements	EN 301 489-1 & -5 (8 kV contact, 15 kV air discharge)	
Safety Standard	EN 60950-1	
Immunity	EN 61000-4-3 (2006) (10V/m)	

Note\*) Values apply with FEC ON @ BER<10E-3

Note\*\*) Due to radio electronic design, the receiver is about 6 – 15 dB less sensitive on the following frequencies:

403.000, 416.000, 429.000, 442.000, 455.000, 468.000, 409.5875 and 469.200 MHz.

## 2 SATELLINE-EASy 869 TECHNICAL SPECIFICATIONS

RADIO	RECEIVER	TRANSMITTER
Frequency Range	869.4125 – 869.6375 MHz	
Channel Spacing	25 kHz	
Communication Mode	Half-Duplex	
Frequency Stability	<1 kHz	
Modulation	4-FSK	
Radio Compatibility	SATELLINE-3AS 869	
Spurious Radiation	< 2 nW	according to EN 300 220
Sensitivity (BER < 10 E-3)	-111dBm	Note*)
Co-channel Rejection	> -12 dB	Note*)
Adjacent Channel Selectivity	> 52 dB	Note*)
Intermodulation Attenuation	> 60 dB	Note*)
Blocking	> 86 dB	Note*)
Spurious Rejection	> 60 dB	Note*)
Type of Emission		F1D
Carrier power		10, 20, 50, 100, 200, 500 mW
Adjacent Channel Power		according to EN 300 220
Carrier power stability		< ±1.5 dB
DATA MODEM		
Electrical Interface	Port1: RS-232 / Port2: LVTTTL, TTL or RS-232 /422 (depends on the assembly)	
Interface Connector	D-15 female	
Data speed of Serial interface	300 – 38400 bps	
Data speed of Radio Interface	19200 bps (25 kHz channel)	
GENERAL		
Operating voltages	+6 ... +30 VDC	
Power Consumption	<1.2 W (Receive), <3.8 W (Transmit) 0.12 W (Sleep mode), 10 mW (DTR Power save)	
Temperature Ranges	-25 °C ... +55 °C Complies with standards -30 °C ... +65 °C Functional -40 °C ... +75 °C Absolute min./max. -40 °C ... +85 °C Storage	
Antenna Connector	TNC female 50 ohm	
Construction	Aluminium housing	
Size H x W x D	139 mm x 67 mm x 29 mm	
Weight	250 g	
COMPLIANT WITH THE INTERNATIONAL STANDARDS		
RF-requirements	EN 300 220-2	
EMC-requirements	EN 301 489-1 & -3 (8 kV contact, 15 kV air discharge)	
Safety Standard	EN 60950-1	
Immunity	EN 61000-4-3 (2006) (10V/m)	

Note\*) Values apply with FEC ON @ BER<10E-3

## 2.1 Important note for the users of SATELLINE-EASy 869

### **NOTE!**

**SATELLINE-EASy 869 does NOT support all features of SATELLINE-EASy**

Please note that the paragraphs of this user guide describing the features listed below apply only to SATELLINE-EASy unless specifically mentioned.

<b>Feature/Property</b>	<b>SATELLINE-EASy 869</b>	<b>SATELLINE-EASy</b>
Frequency band	869.4125...869.6375 MHz	403...473 MHz
Channel spacing/width	25 kHz fixed	25, 20, 12.5 kHz
Transmitter output	10, 20, 50, 100, 200, 500 mW	100, 200, 500, 1000 mW
Supported radio compatibility options	SATELLINE-3AS	SATELLINE-3AS PacCrest-4FSK PacCrest-GMSK Trimtalk450s PacCrest-FST
Free Channel Scan (FCS)	Not supported	Supported
Channel list	Not supported	Supported
Call sign transmission	Not supported	Supported
Radio requirements specification (see the previous pages)	EN 300 220-2	EN 300 113-2 FCC CFR47 section 90
Operating voltage	+6...+30 V <sub>DC</sub>	+6...+30 V <sub>DC</sub> +3...+9 V <sub>DC</sub>

### 3 SATEL COMPACT-PROOF TECHNICAL SPECIFICATIONS

There is four different models available:

- YM6570 SATEL Compact-Proof: freq. range 403 – 473 MHz with battery
- YM6571 SATEL Compact-Proof: freq. range 403 – 473 MHz without battery
- YM6575 SATEL Compact-Proof: freq. range 869 MHz with battery
- YM6576 SATEL Compact-Proof: freq. range 869 MHz without battery

Down below detailed technical specifications.

Subject	YM6570 and YM6571	YM6575 and YM6576
Frequency range	403 ... 473 MHz	869.4125 ... 869.6375 MHz
Tuning range	70 MHz	10 channels
Channel spacing	12.5 / 20 / 25 kHz selectable	25 kHz fixed
RX Sensitivity / TX power max.	-114 dBm / 1 W	-111 dBm / 500 mW
Interface	RS-232	
Operating voltage	+9 ... +16 Vdc	
Power consumption RX / TX	1.2 W / 7 W	1.2 W / 3.8 W
Data speed radio max. / serial	19200 / 38400 bps	
Connectors	8-pin ODU / 4-pin ODU / TNC female	
Size H x W x D	187 x 84 x 50 mm	
Weight – with battery	850 g	
- without battery	520 g	
IP classification	IP67 (NEMA6)	

#### 3.1 Specification for battery

Subject	Value
Battery type	Panasonic 2S3P, NCR18650PF 7.2 V, 8700 mAh Li-Ion
Operating / Charging Voltage	+9 ... +16 Vdc
Charging time	Empty to full 5.5 hrs (+20 C°)
Charge / discharge cycles	>500 times
Charging temperature	+5 ... +45 C°
Operational temperature	-20 ... +60 C°
Operating times appr.	+60 C° (1 W, TX 100%) 13 h +60 C° (1 W, TX 50%) 22 h -20 C° (1 W, TX 100%) 10 h -20 C° (1 W, TX 50%) 15 h -20 C° (RX only) 44 h
Power consumption, modem OFF state	6 mW

## 4 INTERFACE – CONNECTORS & LEDS

### 4.1 Antenna connector

All models have a single TNC female type antenna connector with impedance of 50 Ohm.

The antenna should always be connected when the power is on. Removing the antenna while the transmitter is on may damage the power amplifier inside the transmitter.

### 4.2 Power supply

SATELLINE-EASy is available in two operating voltage ranges depending on which type of internal power/interface-module has been installed at the factory. The voltage range is marked on the label:

- +6...+30 V<sub>DC</sub> (delivered by default)
- +3...+9 V<sub>DC</sub>

SATELLINE-EASy 869 is available only in +6...+30 V<sub>DC</sub> operating voltage range and SATEL Compact-Proof in +9...+16 V<sub>DC</sub> operating voltage range.

The radio modem must be connected to a power supply with an adequate current output.

A proper fuse should be connected in between the radio modem and the power supply:

Operating voltage range	+3 ... +9 V	+6 ... +30 V	+9...+16 V
Current rating of the fuse	2.5 A slow	1 A slow	1 A slow

Operating voltage range of SATELLIN-EASy is marked as follows:

Type: SATEL-TA13      E2-PF      Y RX TX

Model: SATELLINE-EASy

Input Voltage: 6 - 30V/1A      ==

Freq: 403 - 473 MHz

S/N: 1405 59790

Made by SATEL OY [www.satel.com](http://www.satel.com)  
 Meriniitynkatu 17, FI-24100 FINLAND  
 Made in Finland

Type: SATEL-TA13      E2-PF      Y RX TX

Model: SATELLINE-EASy

Input Voltage: 3-9V/1A      ==

Freq: 403 - 473 MHz

S/N: 1405 00166

Made by SATEL OY [www.satel.com](http://www.satel.com)  
 Meriniitynkatu 17, FI-24100 FINLAND  
 Made in Finland

### 4.3 Serial ports

Before connecting DTE (Data Terminal Equipment) to the radio modem, please make sure that the configuration matches the physical interface (electrical characteristics, timing, direction and interpretation of signals). The radio modem contains two separate serial ports that are designated as **Port 1** and **Port 2**. Only one port at a time can be selected for communication.

**Port 1** - Always RS-232 (Port 1 ON is the default configuration)

**Port 2** – The physical interface depends on which type of internal power/interface-module has been installed at the factory. Available options are:

- RS-232/RS-422 (delivered by default)
- LVTTTL
- TTL

RS-422 interface of the radio modem can be adapted to RS-485 interface by wiring the signals externally, see paragraph *RS-485 interface*.

**NOTE!** WHEN THE MODE-PIN (D15 CONNECTOR PIN12) IS CONNECTED TO GROUND, THE RADIO MODEM IS IN THE PROGRAMMING MODE AND **Port 1** IS THEN IN USE!  
 If **Port 2** is to be used for data transmission, the serial cable must be changed to a suitable type when switching over to the programming mode.  
**NOTE!** SATEL Compact-Proof has only one serial port: RS-232

### 4.4 LED indicators

There are five (5) LED indicators on the front panel of the radio modem that indicate the status of the serial port and the radio interface:



LED	Indication	OFF	Red	Orange	Green
RTS	RTS-line status (D15 Pin 13)	Inactive	Active	-	-
CTS	CTS-line status (D15 Pin 6)	Inactive	Active	-	-
TD	TD-line status (D15 Pin 11) Indicates that the radio modem is receiving data via serial port.	No data	Data	-	Test Tx active
RD	RD-line status (D15 Pin 9) Indicates that the radio modem is sending data via serial port.	No data	Data	-	-
CD	Indicates the status of the radio interface. Note that the status of CD-line (D15 pin 2) may differ from the status of CD LED.	No signal	Transmitter is ON	Noise	Reception

## 4.5 LED indicator for charging

In addition to the five LEDs described above, SATEL Compact-Proof has one more LED showing the charging status.

Charging conditions, charging power connected

Colour	Value
Green	Charging power connected or charging completed
Orange	Charging and battery detect
Blinking orange	Possible defect battery
Blinking green	Charging temperature limit exceeded, charging is not possible at this time

Non charging conditions

Colour	Value
Green	Charging power connected or charging completed
Green	More than 50% of capacity is available. If charging power is present it is used as a primary power source
Orange	Less than 50% of capacity is available
Red	Less than 20% of capacity is available
Fast blinking red	Less than 10% of capacity is available. Connect to a charger immediately
Blinking green	Modem is OFF or no charging power or battery is empty

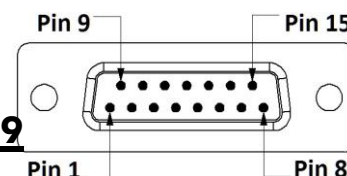

## 4.6 D15 connector SATELLINE-EASy and -EASy 869

### SATELLINE-EASy radio modems: 15-PIN FEMALE D CONNECTOR PINOUT

I/O column below denotes the direction of the signal: "IN" is from DTE (Data Terminal Equipment) to the radio modem. "OUT" is from the radio modem to DTE.

PIN	NAME	I/O	LEVEL	EXPLANATION
<b>1</b>	<b>DTR</b>	IN	0..30V	Data Terminal Ready. The pin can be used to wake-up the radio module from the standby mode. > +3 VDC = ON, < +0.6 VDC or not connected = STANDBY
<b>2</b>	Pin 2 has alternative functions depending on the Port2 configuration, see below.			
	<b>CD</b>	OUT	RS-232	Carrier Detect (if Port2 Interface level is RS-232)
	<b>A'</b>	OUT	RS-422	Port2 Receive Data positive (if Port2 Interface level is RS-422)
	<b>CTS</b>	OUT	TTL	Clear To Send Note*) (if Port2 Interface level is TTL)
LVTTTL			Clear To Send Note*) (if Port2 Interface level is LVTTTL)	
<b>3</b>	Pin 3 has alternative functions depending on the Port2 configuration, see below.			
	<b>RD2</b>	OUT	RS-232	Port2 Receive Data (if Port2 Interface level is RS-232)
		OUT	TTL	Port2 Receive Data (if Port2 Interface level is TTL)

		OUT	LVTTTL	Port2 Receive Data (if Port2 Interface level is LVTTTL)
	<b>B'</b>	OUT	RS-422	Port2 Receive Data negative (if Port2 Interface level is RS-422)
<b>4</b>	Pin 4 has alternative functions depending on the configuration, see below.			
	<b>TD2</b>	IN	RS-232	Port2 Transmit Data (if Port2 Interface level is RS-232)
		IN	TTL	Port2 Transmit Data (if Port2 Interface level is TTL)
		IN	LVTTTL	Port2 Transmit Data (if Port2 Interface level is LVTTTL)
<b>A</b>	IN	RS-422	Port2 Transmit Data positive (if Port2 Interface level is RS-422)	
<b>5</b>	Pin 5 has alternative functions depending on the hardware assembly, see below.			
	<b>RTS</b>	IN	TTL	Request To Send Note*) (if Port2 Interface level is TTL)
			LVTTTL	Request To Send Note*) (if Port2 Interface level is LVTTTL)
<b>B</b>	IN	RS-422	Port2 Transmit data negative	
<b>6</b>	<b>CTS</b>	OUT	RS-232	Clear To Send. This signal indicates that the radio modem serial interface is ready to receive data from DTE. Note*)
<b>7, 8</b>	<b>GND</b>	-		Operating voltage ground / signal ground. Galvanically connected to the modem casing.
<b>9</b>	<b>RD1</b>	OUT	RS-232	Port1 Receive Data to DTE from the radio modem
<b>10</b>	<b>DSR</b>	OUT	RS-232	Data Set Ready. Indicates that the radio modem is ON.
<b>11</b>	<b>TD1</b>	IN	RS-232	Port1 Transmit Data from DTE to the radio modem.
<b>12</b>	<b>MODE</b>	IN	0..30V	<2VDC or connected to ground = Programming Mode >3VDC or Not connected = Data Transfer Mode Note**)
<b>13</b>	<b>RTS</b>	IN	RS-232	Request To Send from DTE. Note*)
<b>14, 15</b>	<b>V<sub>b</sub></b>	-	See specs	Operating Voltage. Depends on the assembled power module: +3...9 VDC (Only for SATELLINE-EASy) / +6...30 VDC
<p>Note! Unused pins can be left unconnected.</p> <p>Note*) RTS and CTS signals apply to the selected Data port (either Port1 or Port2).</p> <p>Note**) Programming Mode is for changing the settings of the radio modem via Programming menu. Normally the MODE line is NOT connected i.e. the modem is in Data Transfer Mode.</p>				

#### 4.7 8-pin ODU and 4-pin ODU SATEL Compact-Proof

SATEL Compact-Proof has a separate connector for data, 8-pin ODU and for power, 4-pin ODU.

	Data connector: 8-pin ODU, MINI-SNAP
1	RTS
2	CTS
3	SGND
4	RXD
5	TXD
6	PROG
7	Not connected
8	Not connected

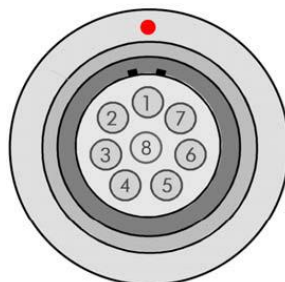

Power connector: 4-pin ODU MINI-SNAP Style G4 size 1	
1	PWR (+)
2	PWR (+)
3	GND
4	GND

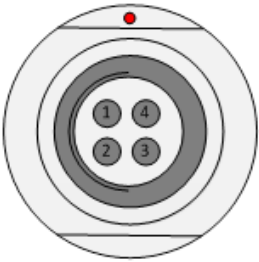

## 5 SERIAL INTERFACE

The radio modem is referred to as DCE (Data Communication Equipment) whereas the device connected to it, typically a PLC or a PC, is referred to as DTE (Data Terminal Equipment). The 15-pin female 'D'-type connector of the radio modem contains the connections required to establish data communication between the radio modem and DTE.

In order to transfer data, the physical interface between DCE and DTE must be compatible and properly configured. This chapter describes shortly the basics of the physical interface options, the related settings and the operation of the serial interface.

The radio modem contains two separate serial ports Port 1 and Port 2:

- Only one port at a time can be selected for communication.
- Port1 is configured ON by default.
- The physical interface of Port 1 is always RS-232.
- The physical interface of Port 2 depends on which type of internal power/interface-module has been installed at the factory and the selected settings.

SATELLINE-EASy - Available serial port interfaces		
Serial Port	Physical interface	Power/Interface module identifier
Port 1	RS-232	Port 1 is always RS-232
Port 2	RS-422/RS-232 (RS-485 Note*)	Module ID: IM01 (Operating voltage +6...+30 V <sub>DC</sub> )
		Module ID: IM03 (Operating voltage +3...+9 V <sub>DC</sub> )
	LVTTL (3.3 V)	Module ID: IM02 (Operating voltage +6...+30 V <sub>DC</sub> )
		Module ID: IM04 (Operating voltage +3...+9 V <sub>DC</sub> )
TTL (5 V)	Module ID: IM05 (Operating voltage +6...+30 V <sub>DC</sub> )	
	Module ID: IM06 (Operating voltage +3...+9 V <sub>DC</sub> )	

SATELLINE-EASy 869 - Available serial port interfaces		
Serial Port	Physical interface	Power/Interface module identifier
Port 1	RS-232	Port 1 is always RS-232
Port 2	RS-422/RS-232 (RS-485 Note*)	Module ID: IM01 (Operating voltage +6...+30 V <sub>DC</sub> )
	LVTTL (3.3 V)	Module ID: IM02 (Operating voltage +6...+30 V <sub>DC</sub> )
	TTL (5 V)	Module ID: IM05 (Operating voltage +6...+30 V <sub>DC</sub> )

Note\*) RS-422 can be adapted to RS-485 externally. See paragraph RS-485 interface.

The handshaking signals apply to the selected serial port (Port 1 or Port 2). The handshaking signals are CD (Carrier Detect), RTS (Ready To Send), CTS (Clear To Send), DSR (Data Set Ready) and DTR (Data Terminal Ready). The physical level of these signals is always RS-232. The wiring and cable connections are illustrated in chapter INSTALLATION.

SATEL Compact-Proof has only one serial port: RS-232.

## 5.1 RS-232 interface (Port 1, Port 2)

RS-232 standard defines the method of transferring binary single-ended data serially between DTE and DCE. Although the standard defines the electrical characteristics, timing and meaning of the signals, as well as the pin out of connectors, it is applied in a multitude of slightly differing ways (e.g. different pin configurations). For this reason different computers and peripherals are not necessarily directly compatible with each other.

RS-232 standard defines transmission lines, in which each single signal line level is referenced to a common ground level. When connecting equipment using RS-232 interface make sure that the equipment are connected together sharing the same ground potential. Major differences in ground potentials may result to large current flow in the ground (GND) wire and may lead to a malfunction or damage the connected devices!

RS-232 has been designed for serial data transfer over short distances (usually less than 15 m). For longer distances, RS-422 or RS-485 is better suited in order to maintain the integrity of data.

## 5.2 RS-422 interface (Port 2)

RS-422 standard defines a serial data transfer method, which is very similar to the RS-232 standard. In RS-422 however, the signal lines are balanced (or differential) transmission lines. A balanced (or differential) transmission line is formed by using two signal wires together to convey each single signal. Because the state of the signal is defined by the mutual voltage difference (hence the name differential), any common mode disturbances induced into the lines will cancel out. The effect of different signals moving in the same cable will also be smaller than in the case of the RS-232. Transmission distance can be considerably longer than when using RS-232 type of connection, and distances of 1 km are possible.

As an example, let's examine the TX-signal: TX-signal will be transmitted using two lines (A and B). A logical "1" corresponds to a situation, where the voltage on line A is greater than the voltage on line B. Correspondingly a logical "0" corresponds to a situation, where the voltage on line A is smaller than the voltage on line B.

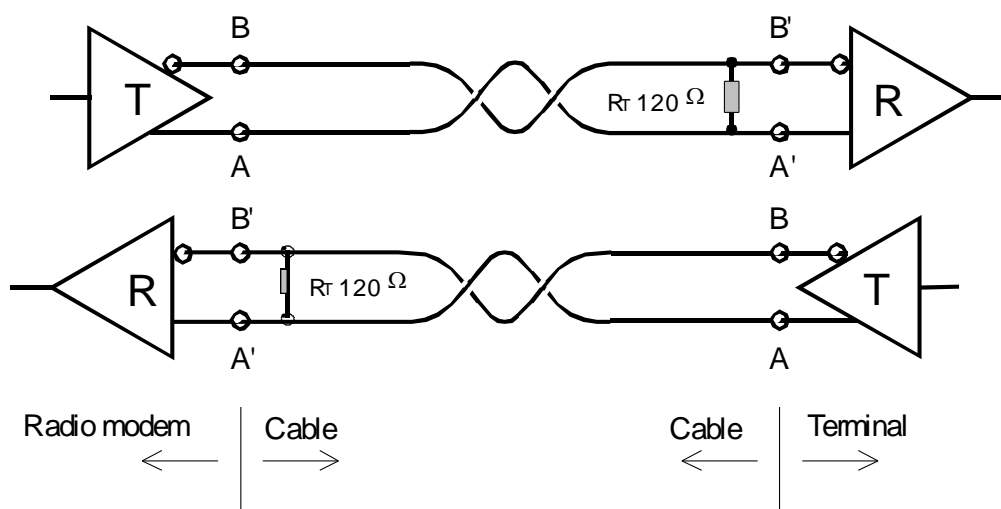

### 5.3 RS-485 interface (Port 2 externally connected)

RS-485 is an extension of the RS-422 standard and enables the connection of more than two devices on to the same bus. Communication is half-duplex, so there is only one cable pair, compared to two when using the RS-422. The RS-485 standard defines the electrical characteristics of the connections in such a way as to prevent possible data contention states as well as cable shorts etc. from harming the devices themselves.

The modem does not have an internal RS-485 interface. Instead, RS-485 can be established by using the RS-422 interface and wiring the signals externally as depicted below.

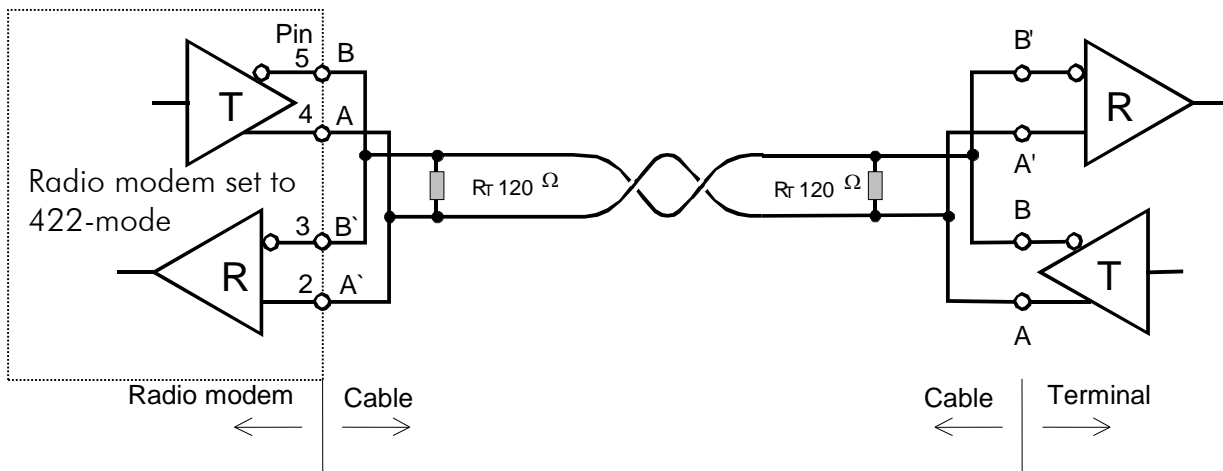

### 5.4 Termination of RS-422/485 lines

Each differential pair of wires is a transmission line. A transmission line must be terminated properly to prevent, or at least minimise, harmful reflections formed between the transmitting and receiving end of the transmission line. A common method of terminating a RS-485 type of transmission line is to connect a so-called termination resistor, between the wires and at both ends of the transmission line. Even when there are more than two devices on the same transmission line, the termination resistors are needed only at the ends of the transmission line. The termination resistor must be selected so that its resistance matches the characteristic impedance of the transmission line as close as possible (typical values range from 100 to 120 Ohm). When using a RS-422 type of connection the termination resistor is connected only at each of the receiving ends. Termination resistors are particularly important when using long transmission lines and/or high data transfer speeds.

## 5.5 Serial data format

The serial interface uses an asynchronous data format. Any character to be transmitted on the serial line contains a start bit, the data bits (7, 8 or 9 bits), an optional parity bit and one or two stop bits. Data bits are transmitted with the least significant bit first, the most significant bit last. For even parity, the number of 1's in the data plus the parity bit equals an even number. For odd parity, this sum is an odd number.

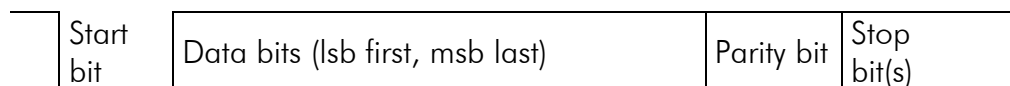

**Example:** The letter C (43 in hexadecimal, 01000011 in binary) is transmitted as shown in the table below when using 8-bit data length:

DATA FORMAT	CHARACTER	CHARACTER LENGTH
8 bit, no parity, 1 stop bit	0110000101	10 bit
8 bit, even parity, 1 stop bit	01100001011	11 bit
8 bit, odd parity, 1 stop bit	01100001001	11 bit
8 bit, no parity, 2 stop bits	01100001011	11 bit
8 bit, even parity, 2 stop bits	011000010111	12 bit
8 bit, odd parity, 2 stop bits	011000010011	12 bit

The overall length of characters (10, 11 or 12 bits) should be taken into account when calculating the data throughput capability of a system. A useful rule of thumb is that the transmission of one character will require roughly one millisecond (1 ms) at 9600 bps.

The serial port settings of the radio modem and the terminal device connected to it must equal - otherwise errors will be introduced into the transferred data.

## 5.6 Handshaking lines

Handshaking signals can be used to control data transfer. For example, the radio modem can inform the DTE that the radio channel is busy, and that it is not allowed to initiate transmission.

A common way of using handshaking signals is to monitor the CTS-line and ignore the others. Usually the terminal device is fast enough to handle the data received by the radio modem, so the use of RTS-line is not necessary.

Handshaking is not needed if the system protocol is designed to prevent collisions (data contention) by the use of polling, or if there is little traffic and also if there is no harm from occasional data contention situations (several radio modems try to transmit at the same time).

### **5.6.1 CTS line**

- CTS (Clear To Send) is a signal from the radio modem to the DTE. It indicates when the radio modem is ready to accept more data from the DTE. The options for CTS line are:
- Clear To Send - CTS line is set active when the radio modem is ready to accept data for transmission. CTS will shift into inactive state during data reception, and at the end of transmission. CTS shifts back into active state either when reception ends or the radio modem has finished data transmission. CTS will also shift into inactive state when the transmit buffer is about to overflow i.e. there is more data coming in from the serial port than the radio is able to transmit.
- TX buffer state - CTS will shift into inactive state only if the radio modem's TX buffer is about to overflow. This typically happens when the transfer speed on the serial interface is greater than on the radio interface, and the size of transmitted messages is large.

### **5.6.2 CD line**

CD (Carrier Detect) is a signal from the radio modem to the DTE. It indicates when there is activity on the radio channel. The options for CD line are:

- RSSI-threshold - CD is active whenever a signal exceeding the level required for reception exists on the radio channel. It doesn't make any difference if the signal is an actual data transmission, a signal of a radio transmitter not belonging to the system, or even an interference signal. CD is also active when the radio modem itself is transmitting.
- Data on channel - CD will switch to active state only after recognition of a valid data transmission. CD will not react to interference signals or noise.
- Always ON - CD is always in the active state. This option can be used with terminal equipment that treats CD line as an indicator of an active connection.
- Ext Antenna Control – CD follows the status of the transmitter. This option can be used for controlling external equipment e.g. antenna switches.

### **5.6.3 RTS line**

The options for RTS-line are:

- Ignored - RTS-line status is ignored.
- Flow control - The radio modem transmits data to the terminal device only when the RTS-line is active. Non-active state of the RTS-line will force the radio modem to buffer the received data. This option is used if the terminal device is too slow to handle data received from the radio modem.

- Reception control - RTS-line controls the reception process of the radio modem. An active RTS-line enables reception (as normal). Non-active RTS-line will interrupt reception process immediately, even if the radio modem is receiving a data packet.

#### **5.6.4 DTR line**

DTR (Data Terminal Ready) has a special function in the radio modem - it can be used as an external ON/OFF switch for power saving purposes.

The radio modem is:

- ON, if the voltage at the DTR pin is more than +3 VDC
- OFF, in the Standby Mode if the voltage at the DTR pin is less than +0.6 VDC

NOTE: If the DTR pin is not connected, the radio modem is ON.

#### **5.6.5 DSR line**

DSR (Data Set Ready) is a signal from the radio modem to the DTE. It indicates that the radio modem is powered up. DSR is typically ignored.

### **5.7 Pause length**

The modem recognises a pause on the serial line (a pause is defined as a time with no status changes on the RS-232 interface TD-line). The pause detection is used as criteria for:

End of radio transmission - When the transmit buffer is empty and a pause is detected, the modem stops the transmission and will then change the radio to the receive mode.

SL command recognition - For a SL command to be valid, a pause must be detected before the actual command character string.

User address recognition - In order for the start character to be detected, a pause must precede it in transmission.

Traditionally, in asynchronous data communication, pauses have been used to separate serial messages from each other. However, the use of non-real-time operating systems (frequently used on PC-type hardware) often adds random pauses, which may result in the user data splitting into two or more separate radio transmissions. This may cause problems especially in the systems including repeater stations.

In order to match the operation of the radio modem to the user data, the Pause length parameter can be adjusted on the programming menu. It may have any value between 3 and 255 characters. The default value is 3 characters.

Notes:

The absolute time of Pause length is depending on the serial port settings. For example, 1 character is ~1.04 ms at 9600 bps / 8N1 (10 bits).

The maximum absolute time is always 170 ms independent from the value of the Pause length given in the set-up.

An increase in the Pause length increases the round trip delay of the radio link correspondingly; this is due to the fact that the radio channel is occupied for the time of the Pause length after each transmission (the time it takes to detect a pause). If this is not acceptable, the TX delay setting may also be useful in special cases.

## **5.8 Data buffering**

Whenever the radio modem is in *Data Transfer Mode* it monitors both the radio channel and the serial interface. When the terminal device starts data transmission the radio modem switches to transmission mode. At the beginning of each transmission a synchronisation signal is transmitted and this signal is detected by another radio modem, which then switches into receive mode. During the transmission of the synchronisation signal the radio modem buffers data into its memory. Transmission ends when a pause is detected in the data sent by the terminal device, and after all buffered data has been transmitted. When the serial interface speed is the same or slower than the speed of the radio interface, the internal transmit buffer memory cannot overflow. However, when the serial interface speed exceeds the speed of the radio interface, data will eventually fill transmit buffer memory. In this instance, it will take a moment after the terminal device has stopped transmission of data for the radio modem to empty the buffer and before the transmitter switches off. The maximum size of transmit buffer memory is one kilobyte (1 kB). If the terminal device does not follow the status of the CTS-line and transmits too much data to the radio modem, the buffer will be emptied and the transmission is restarted.

In the receive mode, the buffer works principally in the above described way thus evening out differences in data transfer speeds. If the terminal device transmits data to a radio modem in receive mode, the data will go into transmit buffer memory. Transmission will start immediately when the radio channel is available.

## 6 RF INTERFACE

All modem types have a single TNC female type antenna connector with impedance of 50 Ohm.

SATELLINE-EASy and SATEL Compact-Proof (403 – 473 MHz) offers the radio settings for user to select:

- Channel spacing: 25 kHz, 20 kHz or 12.5 kHz
- Frequency can be any 6250 Hz divisible frequency between 403...473 MHz in case the Channel Spacing is 25 kHz or 12.5 kHz  
(for example 403.000 MHz, 403.006250 MHz, 403.012500 MHz)
- Frequency can be any 10000 Hz divisible frequency between 403...473 MHz in case the Channel Spacing is 20 kHz
- (for example 403.000 MHz, 403.010 MHz, 403.020 MHz)

SATELLINE-EASy 869 and SATEL Compact-Proof (869 MHz freq.range) has a fixed 25 kHz channel spacing. The user can select one of the ten possible frequencies:

- 869.4125 MHz
- 869.4375 MHz
- 869.4625 MHz
- 869.4875 MHz
- 869.5125 MHz
- 869.5375 MHz
- 869.5625 MHz
- 869.5875 MHz
- 869.6125 MHz
- 869.6375 MHz

The data speed of the radio interface depends on the radio channel spacing:

- 25 kHz channel => 19200 bps
- 12.5/20 kHz channel => 9600 bps

The data speed over-the-air is irrespective of the data speed of the serial interface. If the two differ from each other, the radio modem will buffer the data (max 1 kB) temporarily.

Please note that any communication link introduces an extra time delay called latency that affects the system performance. It is the minimum time experienced by the data between the moment when the data appears at the serial interface of the transmitting modem and the receiving modem. Appendix B presents measured transfer delays in details.

## 6.1 Transmitter

The output power of the transmitter is adjustable (see the table below for available values). The greatest allowable power depends on limits set by local authorities, which should not be exceeded under any circumstances. The output power of the transmitter should be set to the smallest possible level such that it still ensures error free connection under variable conditions. Excessively high output power levels used in short link spans can cause interferences and affect to the overall operation of the system.

Transmitter output power levels of SATELLINE-EASy, -EASy 869 and SATEL Compact-Proof			
Output power (mW)	Output power (dBm)	403-473 MHz	869.4125 – 869.6375 MHz
10 mW	+10 dBm		✓
20 mW	+13 dBm		✓
50 mW	+17 dBm		✓
100 mW	+20 dBm	✓	✓
200 mW	+23 dBm	✓	✓
500 mW	+27 dBm	✓	✓
1000 mW	+30 dBm	✓	

The antenna (or a 50 Ohm attenuator) should be always connected to the antenna connector while the transmitter is being used in order to guarantee the maximum lifetime of the transmitter.

### NOTE!

Setting the transmitter output power to such a level that exceeds the regulations set forth by local authorities is strictly forbidden. The setting and/or using of non-approved power levels may lead to prosecution. SATEL and its distributors are not responsible for any illegal use of its radio equipment, and are not responsible in any way of any claims or penalties arising from the operation of its radio equipment in ways contradictory to local regulations and/or requirements and/or laws.

## 6.2 Receiver

The sensitivity of the receiver depends on the channel spacing of the radio modem (=data speed of the radio interface) and on the mode of the FEC (error correction).

Receiver sensitivity			
Frequency range	Channel Spacing	FEC OFF	FEC ON
403 – 473 MHz	25 kHz	-108 dBm	-111 dBm
	20 kHz	-111 dBm	-114 dBm
	12.5 kHz	-111 dBm	-114 dBm
869.4125 – 869.6375 MHz	25 kHz	-108 dBm	-111 dBm

The radio modem measures the received signal strength (RSSI) of the receiver constantly. The Signal Threshold setting determines the received signal level above which the search for the radio messages is active. It is recommended that values given in the table above are used as a basis. If the threshold is set too low (the CD LED is ON constantly), it is possible that the receiver is trying to synchronise itself with noise. In such a case the actual data transmission might remain unnoticed. If the threshold is set too high, the weak data transmissions will be rejected although they could be otherwise receivable. Signal threshold should only be changed for a reason - for example in the following cases:

Continuous interference is present and the desired signal is strong. In this case the signal threshold can be increased to prevent the modem from synchronising to the interfering signal(s) and /or possible noise.

Maximum sensitivity should be achieved and the desired signal is very weak. In this case the sensitivity could increase by decreasing Signal threshold. This type of situation is usually a sign of a poorly constructed radio network / contact. Bit errors and momentary loss of signals can be expected in this kind of a situation. Some data might be successfully transferred.

The radio modems equipped with an LCD display show the RSSI of the last received message in dBm units. The RSSI can be requested also locally by using a special SL command (SL@R?). The RSSI value is available 7s after the receiving the message. After that the value is returned to zero.

## 6.3 Priority RX/TX

Priority setting selects the priority between reception and transmission. The setting can be changed in Programming Mode. By default, transmission has higher priority than reception i.e. the default value is Priority TX.

Priority TX means that a terminal device attached to a radio modem decides the timing of the transmission. The transmitter is immediately switched on when the terminal device starts to output data. Should reception be in progress, the radio modem will stop it and change to a transmit state. There is no need to use any handshaking for the control of timing.

Priority RX means, that a radio modem tries to receive all data currently in the air. If a terminal device outputs data to be transmitted (or an SL command) it will be buffered. The radio modem will

wait until the reception has stopped before transmitting the buffered data. This will result in timing slacks to the system, but decreases the number of collisions on the air; this is particularly useful in systems based on multiple random accesses.

## **6.4 Forward Error Correction (FEC)**

FEC improves the reliability of data transfer over the radio by adding additional correction information to the radio messages. Based on that information, the receiving radio modem will be able to correct erroneous bits provided the ratio of erroneous and correct bits is reasonable. However, the use of FEC decreases the data throughput, because the amount of transmitted data increases about 30 % (see Appendix B). FEC should be used on long distance links and/or if the radio channel is "noisy" in other words suffering from interfering signals.

**NOTE!** All radio modems, which are to communicate with each other, must have the same setting for FEC (ON or OFF). If the transmitting radio modem and the receiving radio modem has different settings, data will not be received.

## **6.5 Error checking**

When the error checking is switched on, the radio modem will add a checksum to the transmitted data. When the data is received, the checksum is verified before data is forwarded to the serial port. There are two different options for error checking that can be accessed in the Additional setup menu in the Programming Mode:

*Error check* checks data only partially while data is received.

*Full CRC16 check* adds two checksum characters at the end of the user data message. At the reception end the receiver receives first the whole package and if the checksum matches the data message is forwarded to the serial port. If Full CRC16 check is selected it must be set ON for all radio modems in the same network. Otherwise the checksum characters appear at the end of user message on the serial port.

## **6.6 TX delay**

The radio modem can be configured to delay the beginning of a radio transmission by 1...65000 ms. The function can be used to prevent packet contention in a system, where all substations would otherwise answer a poll of a base-station simultaneously. During this delay data sent to the radio modem is buffered. Even when the priority setting is "RX", the radio modem is prevented to change over to the receiving mode during the period of the TX delay. If TX delay is not needed, its value should be set to 0 ms.

## **6.7 Separate RX/TX-frequencies**

Modem can transmit (TX-frequency) and receive (RX-frequency) on separate frequencies. The switch between the frequencies introduces an extra 40 ms delay in the data transfer that must be taken account when designing the system.

## **6.8 Free Channel Scan (FCS)**

**NOTE!** Free Channel Scan (FCS) is not applicable to modems using 869.4125 – 869.6375 MHz frequency range.

Free Channel Scan (FCS) is designed for one-way transmission between one transmitter and one or more receivers when there are at least two different radio frequencies available. The transmitter monitors the noise level of the channels between the transmissions and finds the best transmission channel. The receivers scan and follow the frequency of that particular transmitter consequently. A more detailed description of FCS function and FCS terminal software is available from the manufacturer or from the nearest distributor.

## **6.9 User data whitening**

In some cases, if the user data includes a large number of constant characters, additional bit errors may appear. The use of error correction (FEC) is recommended in such cases. If that is not possible, the Data whitening feature can be used to improve the reliability of data transfer. The feature is set on/off in the programming mode.

**NOTE!** All radio modems, which are to communicate with each other, must have the same setting for Data whitening (ON or OFF). If the transmitting radio modem and the receiving radio modem has different settings, data will not be received correctly.

## **6.10 Pacific Crest and TRIMTALK compatibility**

**NOTE1** Pacific Crest and TRIMTALK compatibility is not applicable to modems using 869.4125 – 869.6375 MHz frequency range.

SATELLINE-EASy and SATEL Compact-Proof supports additional to the original SATELLINE-3AS data transfer also:

- Pacific Crest FST compatible data transfer over the air, if the opponent Pacific Crest modems operate in the transparent mode/FEC ON/Scrambling ON that is the most common setup among RTK applications. The other modes are currently not supported.
- TRIMTALK® 450s compatible data transfer over the air.

SATELLINE-EASy and SATEL Compact-Proof radio modem provides the following radio compatibility options:

- SATELLINE-3AS      Original SATELLINE-3AS data transfer mode (Default)
- PacCrest-4FSK      Transparent mode/FEC ON/Scrambling ON (Option 1)
- PacCrest-GMSK      Transparent mode/FEC ON/Scrambling ON (Option 2)
- TrimTalk450s(P)      Trimtalk450s GMSK Rx fitted to PacCrest transmitters (Option 3)
- TrimTalk450s(T)      Trimtalk450s GMSK Rx fitted to Trimble transmitters (Option 4)
- PacCrest-FST      (Option 5)

*Notes:*

Supported compatibility options may vary depending on the model and factory configuration.

All radio modems of a system must have identical FEC setting (ON or OFF) in SATELLINE-3AS mode.

The implementation of Radio compatibility options is based on the reference measurements and the available public data of the following radio modems manufactured by Pacific Crest Corporation: ADL, RFM96W, PDL HPB, PDL LPB. TRIMTALK is a trademark of Trimble Navigation Ltd.

## **6.10.1 Settings in compatibility modes**

In order to use the Pacific Crest/TRIMTALK modes implemented in SATELLINE modems:

PACIFIC CREST modems must have:

- Protocol Mode
- Transparent w/EOT Timeout (when using Pacific Crest modulations)
- TrimTalk 450s (when using TRIMTALK GMSK modulation)
- Modulation Type depends on the system
- GMSK (default, always selected when using TRIMTALK 450s mode)
- 4-Level-FSK
- FEC = ON
- Scrambling = ON
- Data Security Code set to = 0 (=not used)
- Local Address= 0...254 (0 by default)

Pacific Crest modems receive messages from SATELLINE modems that have their TX1 address matching the Local Address.

Remote address=0...255 (255 by default, that is the broadcast address to be received by all). SATELLINE modems receive the message from a Pacific Crest radio, provided their RX1 address matches the Remote Address of a Pacific Crest transmitter (or if the message has the broadcast address 255).

SATELLINE modems must have the following key settings:

- FEC OFF (because the FEC here means SATEL 3AS FEC, not Pacific Crest/TRIMTALK FEC )
- Error check OFF
- Full CRC16 check OFF
- Radio Compatibility Option 1 in case of Pacific Crest 4-FSK
- Radio Compatibility Option 2 in case of Pacific Crest GMSK
- Radio Compatibility Option 3 in case of TRIMTALK GMSK

When TX address is selected ON, then TX1 address is used like PDL Remote address that is the destination address for the transmitted messages. Default value is 0x00FF (=255) (note the hexadecimal format of the setting).

When RX Address is selected ON, then RX1 address is used like PDL Local address. Default value is 0x0000 (=0) (note the hexadecimal format of the setting).

Addresses are NOT applicable in TRIMTALK 450s mode so SATELLINE modems must have their RX/TX addresses OFF with Option3.

The configuration tools and settings are different between SATELLINE and Pacific Crest modems: Pacific Crest modems are configured via the serial port using PDLCONF Windows™ program that sends binary control messages to the serial port of the modem.

SATELLINE-EASy radio modems are configured via the serial port using any ordinary terminal program or SATEL Configuration Manager PC-program.

The table below shows the analogy of settings between Pacific Crest and SATELLINE radio modems (status in firmware version v3. 46.3).

<b>Pacific Crest setting</b>	<b>Corresponding SATELLINE setting</b>
Identification: Owner	not implemented
Identification: Channel Bandwidth	Channel spacing
Identification: RF Power	TX power
Radio Link: Channel Selection Type (Manual)	Radio frequency
Radio Link: Current Channel	Radio frequency
Radio Link: Link Rate	Radio compatibility mode and channel spacing determine the link rate
Radio Link:Modulation Mode	Radio compatibility
Radio Link:Scrambling	ON by default
Radio Link:Transmit Retries	not implemented
Radio Link:TX ACK Timeout	not implemented
Radio Link:Cdma Monitoring	Priority (RX=ON, TX=OFF) Default: RX
Radio Link: AutoBase/AutoRover	not implemented
Radio Link:Digisquelch	Signal threshold
Radio Link:Forward Error Correction	ON by default Note: SATELLINE-EASy FEC must be OFF!
Radio Link:Local Address (0 by default)	Primary RX address (RX1) (OFF by default)
Radio Link:Remote Address (255 by default)	Primary TX address (TX1) (OFF by default)
Serial Interface:Protocol Mode	Radio compatibility
Serial Interface:BREAK to Command	not implemented
Serial Interface:Modem Enable: Yes	not applicable
Serial Interface:Soft Break Enable	not implemented
Serial Interface:EOT value (in 0.01s units)	Pause length (in serial port byte intervals)
Serial Interface:Digipeater Delay	not implemented
Serial Interface:Local Node Repeater	not implemented
Frequency Table	Radio frequency
Data Security Code (must be 0=not used)	not implemented
<p>Potential conflicts:</p> <p>FEC setting applies only to the SATELLINE-3AS mode, the other radio compatibility modes have their own FEC bindings (although some previous or special firmware versions differ in the way FEC setting is handled - in case of doubt please contact technical support)</p> <p>Pacific Crest Local/Remote addresses are supported in the firmware versions starting from v3.46.3</p> <p>Repeater function is supported only in the firmware versions starting from v3.46.3</p> <p>Error check and Full CRC16 check must be OFF in SATELLINE modem</p> <p>FCS (Free Channel Scanning) feature is not supported by Pacific Crest radios</p> <p>Message Routing is not supported by Pacific Crest radios</p> <p>SATELLINE RX/TX addressing does not use ARQ scheme like Pacific Crest radios.</p>	

## **6.10.2 Repeater function**

The implemented Pacific Crest/TRIMTALK modes support also the repeater function. The repeater function is configured either by using the SL commands:

- "SL@M=R" (Repeater ON)
- "SL@M=O" (Repeater OFF)

or by selecting Repeater OFF/ON in the Additional setup-> Repeater programming menu.

Note 1. The repeater modem passes TRIMTALK messages also to its serial port unlike for example Pacific Crest PDL modems.

Note 2. If error correction is ON (FEC ON) and TRIMTALK mode is activated by using "SL@S=3" command, the firmware automatically switches SATEL FEC OFF temporarily, and turns it back at the mode return.

## **6.10.3 Support for Local / Remote addresses**

If the modem has TX address ON then primary TX address is handled in the same way as Remote address in Pacific Crest PDL modems. The default value is 0x00FF (255 in decimal format) i.e. the broadcast address.

If the modem has RX address ON then primary RX address is handled in the same way as PDL Local address in Pacific Crest PDL modems. The default value is 0x0000 (0 in decimal format). SATELLINE modem needs to have TX Delay 50ms or more in order to avoid messages from colliding in case it is to be placed in a Pacific Crest system that uses addressing and acknowledging scheme.

In case only broadcast messages are used (like in RTK applications) there is usually no need for TX Delay, except if the transfer delays identical to Pacific Crest modems are preferred – in such cases an appropriate value of TX Delay is 34 ms.

Note 1. SATELLINE-modems do not support Pacific Crest retransmit/acknowledge scheme. However, that has no effect in RTK applications because they utilize only broadcast messages.

#### 6.10.4 Transmission delays

The original SATELLINE-3AS is the fastest mode – the transfer delays are presented Appendix B.

In the PacCrest-4FSK, PacCrest-GMSK and Trimtalk450s modes the whole message is first read from the serial port. The end of the message is detected when there is a pause in data. After that data is framed and transmitted over the radio. Likewise the reception is done fully before outputting the message to the serial port.

Symbol rates of the compatibility modes		
The actual raw data rate is appr. 2/3 of the symbol rate.		
Compatibility mode	Symbol rate on 12.5 kHz channel	Symbol rate on 25 kHz channel
PacCrest 4FSK	9600 bps	19200 bps
PacCrest GMSK	4800 bps	9600 bps
Trimtalk450s	4800 bps	9600 bps
PacCrest FST	9600 bps	19200 bps

The typical latency vs. the size of a message is shown in the tables below for each radio compatibility mode. The delays are measured from the end of transmitted data to the end of received data on the serial interface.

Pacific Crest 4FSK mode on 12.5 kHz channel - Transfer delays				
Bps	1 byte	10 bytes	100 bytes	500 bytes
9600	74 ms	82 ms	302 ms	1293 ms
19200	73 ms	77 ms	249 ms	1031 ms
38400	72 ms	74 ms	222 ms	900 ms

Pacific Crest 4FSK mode on 25 kHz channel - Transfer delays				
Bps	1 byte	10 bytes	100 bytes	500 bytes
9600	43 ms	51 ms	208 ms	911 ms
19200	41 ms	46 ms	155 ms	650 ms
38400	39 ms	43 ms	127 ms	519 ms

Pacific Crest GMSK mode on 12.5 kHz channel - Transfer delays				
Bps	1 byte	10 bytes	100 bytes	500 bytes
9600	93 ms	101 ms	445 ms	2011 ms
19200	91 ms	97 ms	393 ms	1750 ms
38400	91 ms	92 ms	366 ms	1619 ms

Pacific Crest GMSK mode on 25 kHz channel - Transfer delays				
Bps	1 byte	10 bytes	100 bytes	500 bytes
9600	52 ms	62 ms	281 ms	1272 ms
19200	50 ms	55 ms	226 ms	1009 ms
38400	48 ms	51 ms	198 ms	878 ms

Trimtalk450s modes on 12.5 kHz channel - Transfer delays				
Bps	1 byte	10 bytes	100 bytes	500 bytes
9600	153 ms	177 ms	421 ms	1505 ms
19200	151 ms	172 ms	368 ms	1244 ms
38400	151 ms	168 ms	341 ms	1113 ms

Trimtalk450s modes on 25 kHz channel - Transfer delays				
Bps	1 byte	10 bytes	100 bytes	500 bytes
9600	82 ms	98 ms	267 ms	1017 ms
19200	80 ms	93 ms	215 ms	756 ms
38400	79 ms	89 ms	187 ms	625 ms

Radio compatibility Option 5 - Pacific Crest FST on 12.5 kHz channel				
Bps	1 byte	10 bytes	100 bytes	500 bytes
9600	47 ms	71 ms	261 ms	1145 ms
19200	45 ms	64 ms	207 ms	883 ms
38400	48 ms	65 ms	184 ms	756 ms

Radio compatibility Option 5 - Pacific Crest FST on 25 kHz channel				
Bps	1 byte	10 bytes	100 bytes	500 bytes
9600	31 ms	48 ms	190 ms	840 ms
19200	29 ms	41 ms	136 ms	578 ms
38400	28 ms	38 ms	109 ms	447 ms

## 7 TEST MODES

The radio modem can be switched to the Test Mode in which it will send test messages on the radio. Test messages can be utilized for example when directing antennas during system installation. The transmitting radio modem needs only a power supply and an antenna in the test mode but no external terminal device.

If the test mode has been set ON, the radio modem starts to transmit test messages immediately after a reset or a power-up. Test messages are treated as normal data at the receiver side. The recommended data speed at the serial port of the receiving radio modem is 38400 bps @ 25 kHz radio channel or 19200 bps @ 12.5 kHz.

### 7.1 Short block test

In this test mode the radio modem sends a short test message that is preceded by a consecutive number and terminated by the Carriage Return and Line Feed characters. The test messages are repeated continuously at 1 second intervals. The short block test is suitable for running radio link tests. Reception of data can be monitored using a suitable terminal program.

Example of short data blocks:

```
00 This is a testline of SATELLINE-3AS radio modem  
01 This is a testline of SATELLINE-3AS radio modem
```

### 7.2 Long block test

In this test mode the radio modem transmits a test message continuously for 50 s. After 10 s break the test transmission is started again. The transmission sequence is repeated continuously. The long block test can be used in order to measure the transmitter output power, standing wave ratio (SWR) of the antenna system or RSSI (Received Signal Strength Indicator) level at the receiver stations. RSSI can be monitored easily on the LCD display of the receiving modem or by using SL command "SL@R?".

Example of a long data blocks:

```
99 This is a long testline of SATELLINE-3AS radio modem  
00 This is a long testline of SATELLINE-3AS radio modem
```

Note1. Green TD led indicates active test mode.

Note2. Remember to set the test mode OFF before starting the normal data transfer.

Note3. Message Routing and FCS must be disabled prior to setting the Test mode ON.

## 8 SETTINGS

The configuration of settings can be changed easily in several ways - the next chapters describe the details:

### **SATEL Configuration Manager PC software**

This clear to use software suits in most cases. Additional to other tools, it includes the channel list editor for creating the channel lists.

### **Programming mode menu**

When the radio modem is switched to Programming mode, it outputs a traditional text menu for the user input by using a terminal software (SaTerm, HyperTerminal, TeraTerm, etc.)

### **LCD menu & Push buttons (the models equipped with a display)**

The basic settings are accessible from LCD and push buttons. Some of the functions, for example the Channel list editing or configuration of Message routing is to be performed using PC software.

### **SL commands**

A terminal device can command or configure the radio modem by using special commands. SL commands are applied especially in cases where radio modems are to be integrated seamlessly inside a system behind the integrator's own user interface.

<b>SATELLINE-EASy - List of settings</b>	
Setting	Description and value range
TX frequency	The radio frequency of the transmitter The value must be: <ul style="list-style-type: none"> <li>• 403...473 MHz</li> <li>• less than frequency band upper limits</li> <li>• more than frequency band lower limits</li> <li>• divisible by 6.250 kHz (if Channel spacing is 12.5 or 25 kHz)</li> <li>• divisible by 10 kHz (if Channel spacing is 20 kHz)</li> </ul> Default value: 438.000 MHz
RX frequency	The radio frequency of the receiver The value must be: <ul style="list-style-type: none"> <li>• 403...473 MHz</li> <li>• less than frequency band upper limits</li> <li>• more than frequency band lower limits</li> <li>• divisible by 6.250 kHz (if Channel spacing is 12.5 or 25 kHz)</li> <li>• divisible by 10 kHz (if Channel spacing is 20 kHz)</li> </ul> Default value: 438.000 MHz

Reference Frequency	Nominal frequency to which RX or TX frequencies are referenced to when using SL commands "SL&+=" and "SL&-=". In most cases the setting can be ignored. The value must be in range of 403...473 MHz. Default value: 438.000 MHz
Channel Spacing (Width)	12.5, 20 or 25 kHz Channel spacing defines the frequency difference between adjacent radio channels. In the context of SATELLINE-EASy modems it defines also the width of the radio channel. Default value: 12.5 kHz
Tx Power	Transmitter output power EASy supports 100, 200, 500 or 1000 mW EASy 869 supports 10, 20, 50, 100, 200, 500 or 1000 mW Default values: 1000 mW (EASy) / 500 mW (EASy 869)
Signal threshold	RSSI Signal threshold defines the minimum power level (dBm) of the radio signal to be received. Any transmissions below the threshold level are ignored. Note that the greater the absolute value is the weaker is the signal threshold level (-110 dBm is weaker than -90 dBm). Value range is -80 ... -118 dBm. Default value: -115 dBm
Channel list	Selects whether the list of predefined radio channels is used for the configuration of radio parameters. Default value: Channel list OFF
FCS (Free Channel Scan)	FCS parameters and settings are described in separate technical documentation available from the dealers or SATEL. FCS is not to be mixed with the Channel list and its functions. Default value: Free Channel Scan mode OFF
TX Start Delay	Defines the extra time (0...65000 ms) the radio modem waits before starting to transmit. Data is buffered during the delay. Default value: 0 ms (=no delay)
Radio Compatibility	Defines the radio protocol Options are SATELLINE-3AS, PacCrest-4FSK, PacCrest-GMSK TrimTalk450s (P), TrimTalk450s (T), PacCrest-FST Default value: SATELLINE-3AS
Call Sign	Call sign means that the modem transmits its Call sign ID periodically using Morse keying. Call sign is configured using three settings: a) Call sign mode sets Call sign operation ON/OFF. b) Call sign ID defines Morse code to be transmitted, max. sixteen characters, capital letters and numbers are allowed (lower case letters are converted automatically to uppercase letters). If Call sign mode is not used (OFF) you can enter e.g. "CALLSIGN" for the Call sign ID. c) Call sign timer is the interval (1...30 min) between Call sign transmissions. One Call sign transmission may take several seconds to transmit, depending on the Call sign ID. Default value: Call sign mode OFF

RX Address	See the chapter REPEATER MODE AND ADDRESSING Default value: OFF (Rx Address Disabled)
TX Address	See the chapter REPEATER MODE AND ADDRESSING Default value: OFF (Tx Address Disabled)
RX addressing to RS port	See the chapter REPEATER MODE AND ADDRESSING Default value: OFF
TX address auto switch	See the chapter REPEATER MODE AND ADDRESSING Default value: OFF
Serial port 1 Status	Defines whether Port 1 is ON/OFF Default value: ON
Serial port 1 Interface	RS-232 (fixed)
Serial port 1 Data speed	300, 600, 1200, 2400, 4800, 9600, 19200, 38400 bps Default value: 9600 bps
Serial port 1 Data bits	7, 8, 9 bits Default value: 8 bits
Serial port 1 Parity bit	None, Even, Odd Default value: None
Serial port 1 Stop bits	1 or 2 Default value: 1
Serial port 2 Status	Defines whether Port 2 is ON/OFF. If the interface to be used is anything else but RS-232, Port 2 must be set ON. Default value: OFF
Serial port 2 Interface	Available selections depend on the assembly (type of the interface module inside the radio modem). Alternatives are: RS-232/422 or LVTTTL or TTL Most common value: RS-232???
Serial port 2 Data speed	300, 600, 1200, 2400, 4800, 9600, 19200, 38400 bps Default value: 9600 bps
Serial port 2 Data bits	7, 8, 9 bits Default value: 8 bits
Serial port 2 Parity bit	None, Even, Odd Default value: None
Serial port 2 Stop bits	1 or 2 Default value: 1
CTS handshaking	Defines how CTS line acts, the choices are Clear to send and TX buffer state. Default value: Clear to send
CD handshaking	Defines how CD line acts, the choices are: RSSI-threshold, Data on channel, Always ON and Ext Antenna Control. Default value: RSSI- threshold
RTS handshaking	Defines how RTS line is reacted, the choices are: Ignored, Flow Control, Reception Control Default value: Ignored

Pause length	<p>The radio modem recognizes pauses on the serial line and uses them as criteria for ending the transmission and finding SL commands. The value range is 3...255 bytes.</p> <p>In case the serial port data to be transmitted includes pauses between the characters inside messages, increasing Pause length will help in keeping the message in one part over the radio. In general, the value should be kept as small as possible in order to maximize the performance of the radio system.</p> <p>Default value: 3</p>
Error correction (FEC)	<p>ON/OFF</p> <p>FEC (Forward Error Correction) improves the reliability of data transfer over a noisy radio channel. FEC is recommended in case the link distances are long or if the radio channel is not clean. However, FEC ON decreases the data transfer speed by about 30 %.</p> <p>All radio modems, that are to communicate with each other, must have the same setting for FEC (ON or OFF).</p> <p>Note that FEC setting applies only to the SATELLINE-3AS radio protocol, the other radio compatibility modes have their own FEC bindings (although some previous or special firmware versions differ in the way FEC setting is handled - in case of doubt please contact technical support)</p> <p>Default value: OFF</p>
Error check	<p>ON/OFF</p> <p>Default value: OFF</p>
Repeater	<p>Repeater Mode selects whether the radio modem forwards the received messages over the radio or not.</p> <p>Addressing must be also used in the systems that include more than one repeater, in order to prevent the messages bouncing between the repeater stations.</p> <p>Default value: OFF</p>
SL commands	<p>SL command mode ON/OFF</p> <p>When enabled, the modem can be configured/controlled by using the SL commands.</p> <p>Default value: ON</p> <p>Note: In case SL commands are OFF, the activation of MODE pin is required in order to connect the radio modem and SATEL Configuration Manager Software.</p>
Priority	<p>TX or RX</p> <p>Default value: TX</p>
FullCR16 Check	<p>ON/OFF</p> <p>Default value: OFF</p>
User data whitening	<p>ON/OFF</p> <p>Default value: OFF</p>

LCD Write Lock	<p>OFF (Normal use) allows the user to read and modify the settings via push buttons and LCD display.</p> <p>ON (Read-only) allows the user to read the settings but the modifications are not allowed via push buttons.</p> <p>Default value: OFF</p>
Add RSSI to data	<p>If the function is ON, RSSI information is appended to the received data.</p> <p>Default value: OFF</p>
Region Code	<p>Region code defines the regional settings that firmware uses.</p> <p>US: Starting from the 1st of Jan 2013 FCC regulations state, they will allow transmission on 25 kHz radio channels only if the link rate of the radio is at least 19200 bps.</p> <p>In case Region code is set to US and the active setup violates the above mentioned FCC requirement, the radio modem cuts the transmitter power level to zero (0 W) when transmitting. The radio modem is ensuring it is operating according to the FCC requirement.</p> <p>Default value: No regional settings defined.</p>
Routing	<p>See the chapter MESSAGE ROUTING</p> <p>Default value: Routing mode OFF</p>
Tests	<p>Set ON/OFF</p> <p>Default value: OFF</p>
Customer Info 1	<p>Any arbitrary text (max. 32 characters) can be saved in the setting for identification purposes etc.</p>
Customer Info 2	<p>Any arbitrary text (max. 32 characters) can be saved in the setting for identification purposes etc.</p>
Customer Info 3	<p>Any arbitrary text (max. 32 characters) can be saved in the setting for identification purposes etc.</p>

## 9 SATEL CONFIGURATION MANAGER SOFTWARE

SATEL Configuration Manager (CM) is the PC software for the configuration of SATELLINE-EASy, -EASy 869 and SATEL Compact-Proof.

Minimum requirements: PC (Windows 95, 98, 2000, XP, Vista and Win7) equipped with a COM port (minimum baud rate 9600 bps) and the radio modem to be configured.

The software is available from the dealers or at [www.satel.com](http://www.satel.com).

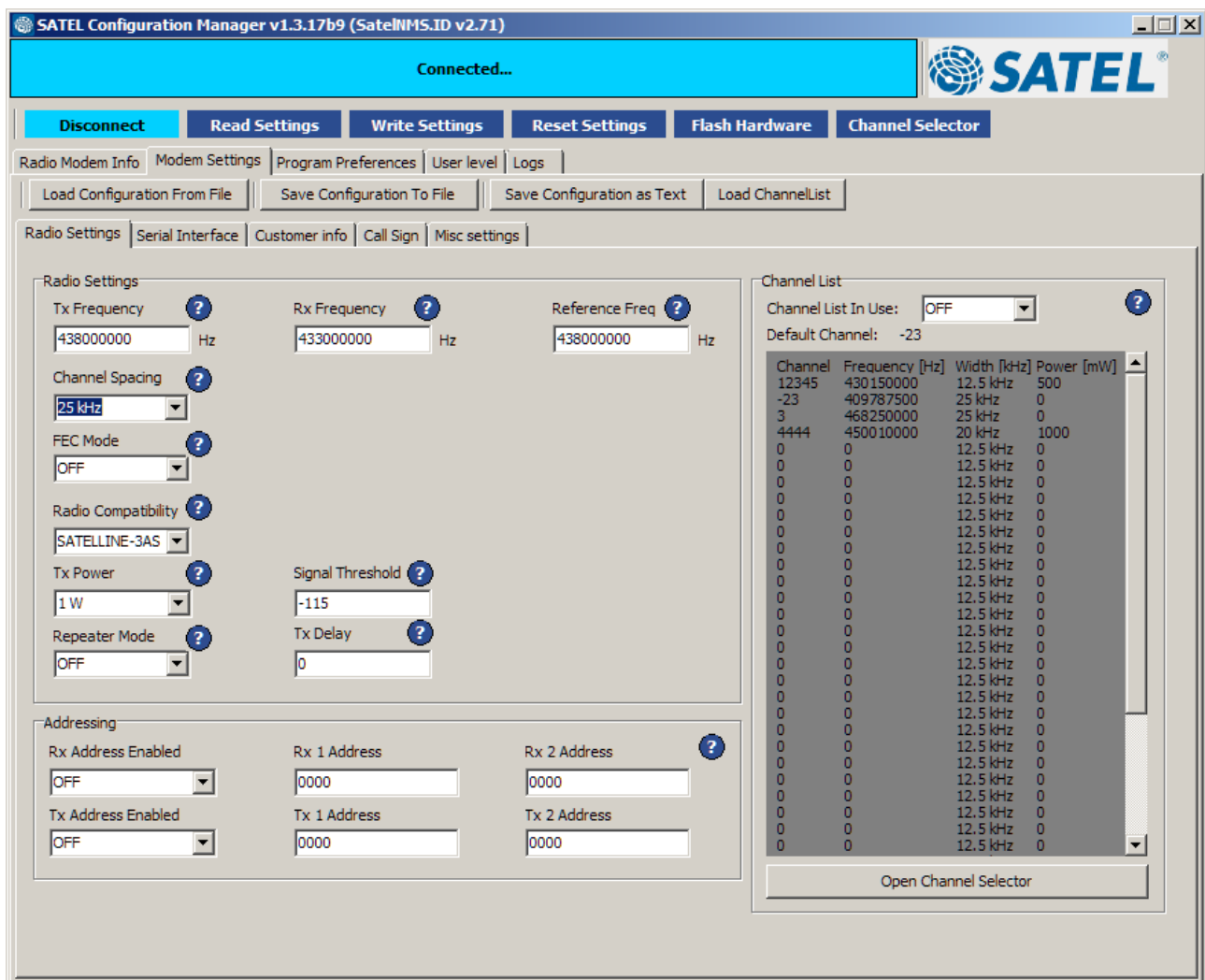

## 10 PROGRAMMING MODE MENU

### 10.1 Programming Mode

The modem needs to be in the *Programming mode* before the *Programming mode menu* activates. The radio modem will shift into the *Programming Mode* by connecting the D15 connector pin 12 to ground (GND) potential. The radio modem will output a menu similar to the example below. Independent from the configuration, the radio modem uses then the serial interface **PORT1** with settings 9600 bps, No parity, 8 data bits, 1 stop bit.

```
-----  
***** SATELLINE *****  
FW: 06.16.3.xx.xx / HW: SPL0005x / PV: 00.xx / IM: 01 / S/N: YMMxxxx  
-----  
Current settings  
-----  
1) Radio frequency TX: 438.0000 MHz / RX: 438.0000 MHz /  
Ref freq: 438.0000 MHz / Spacing 25 kHz  
2) Radio settings Tx power 1000 mW / Signal threshold -115 dBm / FCS OFF /  
TX start delay 0 ms / Compatibility Satel 3AS /  
Call sign OFF / Channel List OFF  
3) Addressing RX address OFF / TX address OFF /  
RX address to RS port OFF / TX address autoswitch OFF  
4) Serial port 1 ON / 9600 bit/s / 8 bit data / None parity /  
1 stop bit  
5) Serial port 2 OFF / 9600 bit/s / 8 bit data / None parity /  
1 stop bit (RS-422)  
6) Handshaking CTS Clear to send / CD RSSI-threshold /  
RTS Ignored / Pause length 3 bytes  
7) Additional setup Error correction OFF / Error check OFF / Repeater OFF /  
SL-commands OFF / Priority TX / Full CRC16 check OFF /  
User Data Whitening OFF / LCDWriteLock OFF /  
Add RSSI to data OFF /  
Region Code Default  
8) Routing OFF  
9) Tests OFF  
A) Restore factory settings  
B) INFO  
E) EXIT and save settings  
Q) QUIT without saving  
  
Enter selection >
```

The recommended setup for using the *Programming mode menu* is NARS-1F adapter, CRS-9 serial/power cable, power supply and SaTerm software. Other suitable terminal programs and cables may also be used. The *Programming mode* can be easily activated the by moving the slide switch in NARS-1F adapter downwards.

## **10.2 How to change the settings in the programming mode menu**

The procedure is as follows:

Connect cables (RS-232 cable connecting Port 1 of the radio modem and PC COM port, power supply cable to power supply).

Switch on the PC and start the terminal program (SaTerm or other applicable software).  
Open a terminal window. Set serial port as 9600 bps, 8 data bits, no parity, 1 stop bit.

Connect MODE pin to ground (in case of NARS-1F adapter, slide the switch away from the radio modem), the radio modem shifts now into the *Programming Mode* and outputs a *Programming menu* (some settings may differ from the ones shown on the previous page).

Make the desired changes to the settings on the menu. The examples below show the idea of using the menus. Pressing "ESC" cancels the value or escapes back to a higher level in the menu.

Save the changes by pressing "E" on the main menu. If you don't want to save the changes, press "Q".

Disconnect MODE pin from ground (if using the NARS-1F adapter, slide the switch towards the radio modem), the radio modem returns to the *Data Transfer Mode*.

### **10.2.1 Example – How to change TX/RX frequencies**

On the main menu, press "1". The following sub-menu will appear:

```
Radio frequency setup
-----
1) Radio frequency   TX: 438.00000 MHz / RX: 438.00000 MHz /
                    Ref freq: 438.00000 MHz / Spacing 25kHz
2) Channel spacing   25kHz

Enter selection or ESC to previous menu >1
```

The next sub-menu appears after pressing "1":

```
Radio TX and RX frequency setup
-----
1) TX and RX frequency
2) TX frequency      438.00000 MHz
3) RX frequency      438.00000 MHz
4) Reference frequency 438.00000 MHz

Enter selection or ESC to previous menu >1
```

Press "1" to change both TX and RX frequencies. The radio modem prompts:

```
Enter new TX and RX frequency (MHz) or ESC to cancel >468.2
```

Type the new value (here 468.200 MHz) and press Enter. TX and RX frequencies will change now.

Escape back to the top level menu. Save the change by pressing "E" for Exit&Save.

### **10.2.2 Restoring factory settings**

The settings that the modem was delivered with can be returned by first selecting "A" in the main menu.

```
Restore factory settings
-----
Do you want to restore factory settings? (Y/N)>Y
```

Further, press "Y" in the sub-menu to confirm the restoral. By pressing "N" (NO) or any other button no changes is done and current settings will remain active. Save the restoral by pressing "E" for Exit&Save on the main menu.

### **10.2.3 Radio modem info**

The header section of the main menu includes info on the build-up (Firmware version (FW), Hardware version (HW), PV=Product variant/version, IM=Interface module (operating voltage voltage range and serial interface options), Serial number (S/N)).

```
-----
***** SATELLINE *****
FW: 06.16.3.60.13 / HW: SPL0005e / PV: 00.04 / IM: 01 / S/N: 114800298
-----
```

Supplementary info is included in the Info submenu.

### **10.2.4 Activating tests**

Tests can be activated by selecting main menu selection "9". Tests are activated by setting the status of the desired test to "ON" and will remain active until the value of the selection in the menu is returned to the value "OFF".

```
Tests setup
-----
1) Short block test      OFF
2) Long block test      OFF
```

NOTE! Message Routing and FCS mode must be disabled in prior to set ON the Test mode.

## 11 LCD & PUSH BUTTONS

The models equipped with a display include an LCD (Liquid Crystal Display) and four push buttons that indicate the status of the radio modem and enable easy modification of the settings without the need for an external terminal. This feature is especially handy on the field conditions.

### 11.1 LCD after power-up

The picture below shows the outlook of the LCD after the power-up in its top level view.

The indicator on the upper left corner has two functions:

- Antenna symbol followed by Received Signal Strength (RSSI) in dBm units. RSSI will be shown for about 7 seconds after the last message has been received.
- “n” symbol followed by the noise level whenever RSSI is not shown i.e. there are no messages from any other compatible radio modem detected.

The indicator on the upper right corner indicates the supply voltage / battery level of the radio modem in Volts.

Y - RSSI indicator

n - Noise level indicator

```

Y-102  012.5V
TX 403.75000 MHz
RX 473.00000 MHz
INFO          SETUP
  
```

Voltage meter

The two lines in the middle revolve automatically every 5 seconds displaying the basic settings as illustrated below.

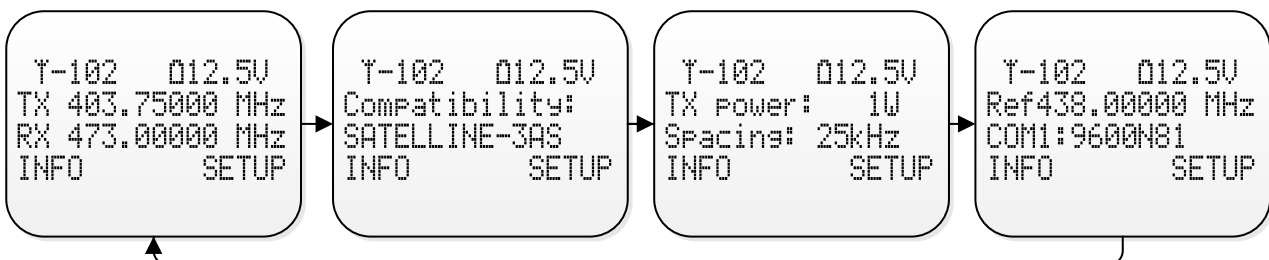

There are two options to proceed from the top level view:

- Press *INFO* button (o) to view the info pages
- Press *SETUP* button (■) to modify the settings

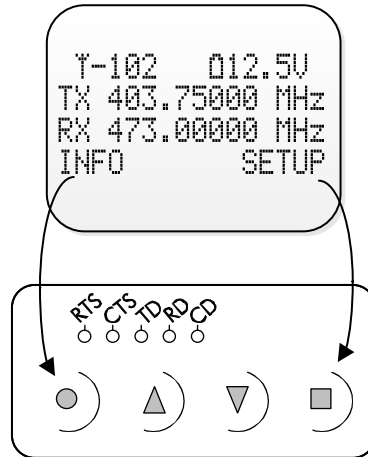

## 11.2 Info pages

```
SATELLINE EASy
S/N:135212345
FW:06.16.3.61
EXIT ▼
```

The first info page shows:

- Product name
- Serial number
- Firmware version

```
TX 438.00000 MHz
RX 438.00000 MHz
Re 438.00000 MHz
EXIT ▲▼
```

You can scroll between the pages using UP(▲) or DOWN(▼)buttons or escape back to the top level by pressing EXIT button.

The second info page:

- Transmitter frequency
- Receiver frequency
- Reference frequency

```
Band 1 limits
Lo 403.00000 MHz
Hi 473.00000 MHz
EXIT ▲▼
```

The third info page:

- Lower limit of Frequency band 1
- Upper limit of Frequency band 1

```
Band 2 limits
Lo 403.00000 MHz
Hi 473.00000 MHz
EXIT ▲▼
```

The fourth info page:

- Lower limit of Frequency band 2
- Upper limit of Frequency band 3

```
Voltage: 6-30V
PORT1:RS232/ON
PORT2:RS232/OFF
EXIT ▲▼
```

The fifth info page:

- Interface and status of serial Port 1
- Interface and status of serial Port 2

```
Board:SPL0005e
IM:01
EXIT ▲
```

The last info page:

- Hardware
- Type of internal interface/power module

## 11.3 How to modify the settings on LCD

After pressing *SETUP* button (■) on the top level view, the list of settings sub-menus appears.

The cursor (>) indicates the active line or the current value of the setting.

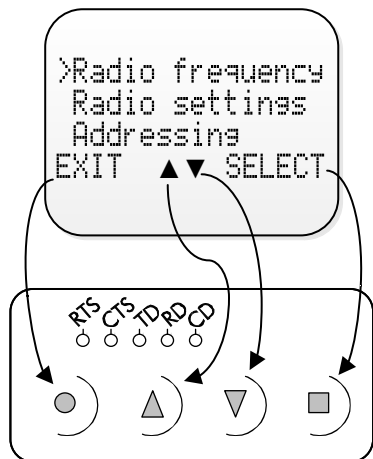

Pressing *DOWN* (▼) button the cursor moves downwards. Depending on the sub-menu, the button also scrolls the digits of numerical values when changing some settings.

Pressing *UP* (▲) button the cursor moves upwards. Depending on the sub-menu, the button also scrolls the digits of numerical values when changing some settings.

Pressing *SELECT/SET/CHANGE/NEXT/YES* (■) button either confirms a selection, sets or changes a value, moves to the next digit or enters a sub-menu depending on the context.

Pressing *EXIT/CANCEL/BACK/NO* button escapes back to the previous higher level in the menu hierarchy or cancels the modification of a setting depending on the particular submenu.

### 11.3.1 Saving the modified settings

After all the desired modifications are done the settings need to be saved in order to make them permanent (until the next modification). This is accomplished by choosing "EXIT" on the top level menu. LCD prompts a message asking a confirmation of the modified configuration.

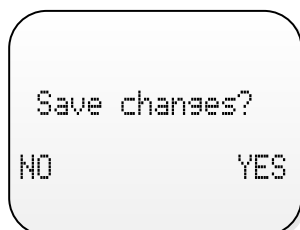

By choosing "YES" the configuration is saved into the non-volatile memory inside the radio modem.

By choosing "NO" the modified settings are cancelled and previous settings remaining in the non-volatile memory.

### 11.3.2 Example – how to change the radio frequency on LCD

```
>Radio frequency
Radio settings
EXIT ▲▼ SELECT
```

Enter the settings menu first by pressing SETUP button (■) on the top level view.

Press ▲ or ▼ until the cursor > points to "Radio frequency" selection and press "SELECT" to move to the next submenu.

```
>TX & RX freq
TX freq
BACK ▲▼ CHANGE
```

Press ▲ or ▼ until the cursor > points to your selection:

- TX & RX freq (in case both TX frequency and RX frequency are to be changed at the same time)
- TX freq (in case only TX frequency is to be changed)
- RX freq (in case only RX frequency is to be changed)

```
Band 1 limits
Lo 403.000000
Hi 473.000000
CANCEL ▼ SET
```

The limits of the Frequency Band 1 will be shown for informative purposes. Likewise the limits of Frequency Band 2 will be shown by pressing ▼.

Press "SET" to activate the window for entering the frequency.

```
New common freq
468.52500 MHz
▲
CANCEL ▲▼ NEXT
```

Increase or decrease the value of each digit by pressing ▲ or ▼. Move to the next digit by pressing NEXT.

Repeat the procedure until the frequency is fully set.

```
Ch accepted
468.200000 MHz
```

Acknowledgement or error message (in case of an invalid value) appears.

```
BACK
EXIT
```

Get back to the top level by pressing BACK.

On the top level press EXIT.

```
Save changes?
NO YES
```

If you want to save the settings as they are now, press YES. If you are not sure or want to cancel the changes, press NO.

### 11.3.3 Example – how to toggle settings ON or OFF on LCD

The value of some ON/OFF type settings is switched on LCD by simply selecting the setting. As an example, the Repeater function is switched OFF or ON below.

```
Handshaking
>Additional
Tests
EXIT ▲▼ SELECT
```

Enter the settings menu first by pressing SETUP button (■) on the top level view.

Press ▲ or ▼ until the cursor > points to "Additional" and press "SELECT" to move to the submenu

```
Error check OFF
>Repeater OFF
SL-commands OFF
BACK ▲▼ CHANGE
```

Press ▲ or ▼ until the cursor > points to "Repeater".

Press "CHANGE" to toggle the value from OFF to ON or vice versa.

```
Error check OFF
>Repeater ON
SL-commands OFF
BACK ▲▼ CHANGE
```

Now the value switched from OFF to ON.

```
BACK
EXIT
```

Get back to the top level by pressing BACK.

On the top level press EXIT.

```
Save changes?
NO YES
```

If you want to save the settings as they are now, press YES.  
If you are not sure or want to cancel the changes, press NO.

### 11.3.4 How to restore the factory settings on LCD

Follow the steps below if you want to return all the settings to the original condition as they were set at the factory.



Enter the settings menu first by pressing SETUP button (■) on the top level view.

Press ▲ or ▼ until the cursor > points to "Factory setup" and press "SELECT" to move to the submenu

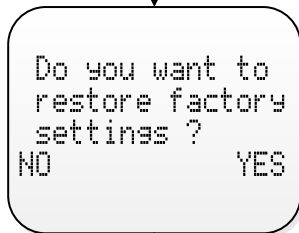

Press "YES" and the configuration will return to the same the radio modem was delivered with.

```
EXIT
SAVE
```

## 12 SL COMMANDS

### 12.1 Changing parameters using the SL COMMANDS

The controlling terminal device can change the configuration settings of a radio modem. This is accomplished with the help of SL commands, which can be used during data transfer. SL commands can be used to change e.g. the frequency or addresses. It is also possible to interrogate a radio modem in order to gain information concerning current settings that are in use. The terminal device is either a PC or a programmable logic (PLC) together with suitable (terminal) program. SL commands must be enabled using *Programming Mode* before they can be used.

An SL command is a one continuous string of characters, which is separated from other data by pauses that are equal or greater than time defined by Pause length parameter in the set-up. No extra characters are allowed at the end of an SL command. Serial interface settings are the same as in data transfer and pin 12 of the serial connector MUST NOT be connected to ground (GND). SL command is properly recognised also in the case when the command string is terminated in <CR> (=ASCII character no. 13, Carriage Return, 0x0d) or <CR><LF> (<LF> = ASCII char. no. 10, Line Feed, 0x0a). If multiple SL commands are sent to the radio modem the next command can be given after receiving the response ("Ok" or "Error") of the proceeding command. In addition, it is recommended to implement a timeout to the terminal software for recovering the case when no response is received from the radio modem.

When the power of a radio modem is switched off the configuration settings of a radio modem always return to values defined initially using the *Programming Mode*, thus resetting any settings changed using SL commands during power on. It is however possible to save settings changed by using SL commands and to make them the new configuration settings.

The radio modem will acknowledge all commands by returning an "OK" (command carried out or accepted) or the requested value, or an "ERROR" (command not carried out or interpreted as erroneous) message.

In case you need more information on the time delays related to the use of SL commands, please contact the manufacturer.

In order to get information of the latest and/or special SL commands please contact SATEL.

## 12.1.1 Addressing related SL commands

Command	Effect and description of command xxx,yyy,zzz,vvv below are hexadecimal number presentations [0000....FFFF]
SL#A?	Show all addresses (RX1, RX2, TX1, TX2) Response: "xxx,yyy,zzz,vvv"
SL#A=xxx,yyy,zzz,vvv	Set RX/TX addresses (RX1, RX2, TX1, TX2)
SL#I?	Get primary addresses (TX1, RX1) Response: "zzz;xxx"
SL#I=xxx	Set all addresses (RX1, RX2, TX1, TX2) to value xxx
SL#P?	Get primary addresses (TX1, RX1) Response: "zzz;xxx"
SL#P=zzz,xxx	Set primary transmit address (TX1) to value zzz and primary receive address (RX1) to value xxx
SL#Q?	Get TX address mode Response: "0" = TX address OFF or "1" = TX address ON
SL#Q=x	Set TX address ON/OFF. Values of x are: 0=TX address OFF 1=TX address ON
SL#R?	Get primary receive address (RX1) Response: "xxx"
SL#R=xxx	Set receive addresses (RX1, RX2) to value xxx
SL#S?	Get secondary transmit address (TX2) and secondary receive address (RX2) Response: "vvv;yyy"
SL#S=vvv,yyy	Set secondary transmit address (TX2) to value vvv and secondary receive address (RX2) to value yyy
SL#T?	Get primary transmit address (TX1) Response: "zzz"
SL#T=xxx	Set transmit addresses (TX1, TX2) to value xxx
SL#W?	Get RX address mode Response: "0" = RX address OFF or "1" = RX address ON
SL#W=x	Set RX address ON/OFF. Values of x are: 0=RX address OFF 1=RX address ON

## 12.1.2 Channel list related SL commands

Command	Effect and description of command
SL\$A=1	Go to channel list default channel
SL\$C?	Get number of channels in channel list Response: decimal number
SL\$C=n	Set number of channels in channel list, n is decimal number, "SL\$C=0" clears channel list
SL\$D?	Get channel list default channel number Response: decimal number
SL\$D=n	Set channel list default channel, n is channel number
SL\$E=1	Search free channel Modem searches for next traffic-free channel. Listening time of traffic is about 2 seconds Modem shows next free channel by activating command again Response: "OK" followed by "channel n is free" Value of n is channel number of next free channel on channel list
SL\$F?	Get active channel number Response: decimal number
SL\$F=n	Set modem to channel number n in channel list
SL\$L?nn	Get channel info. Index nn=[0...(number of channels-1)] Response: Channel number, Frequency, Channel width, Tx Power For example: "CH 1, 430.150000 MHz, 25.0 kHz, 0 mW\0D"
SL\$L=info	Set channel info. Format is SL\$L=laa,Nbbbbbb,Fccccccccc,Wddddd,Peeee<CR> where capital letter marks parameter field and the following decimal number presents its value. aa = Index (0...39) bbbbbb = Channel number (-32767...32767) ccccccccc = Tx/Rx Frequency in MHz (only numbers or "." allowed, "," is not allowed) ddddd = Channel spacing/width in kHz (12.5, 20 or 25) eeee = Transmitter power in mW (0...35000) (modem rounds the value to the closest applicable) Note: 0 means "don't care" value for power.
SL\$M?	Get Channel list mode Response: "0" = Channel list mode OFF or "1" = Channel list mode ON
SL\$M=x	Set Channel list mode. Values of x are: 0 = Channel list mode OFF 1 = Channel list mode ON
SL\$R?	Get listening time (seconds) of Search free channel function Response: decimal number
SL\$R=n	Set listening time (seconds) of Search free channel function
SL\$\$=1	Set channel scanning mode When activated, modem scans channels one by one and saves RSSI readings to memory Response: "OK" followed by channel/RSSI info For example: "OKCH 6 -122 dBm, CH 22 -121 dBm, CH 10003 -122 dBm, "

### 12.1.3 Serial port related SL commands

Command	Effect and description of command
SL%B?	Get serial data parameters Response: baud rate, character length, parity, number of stop bits (for example "38400, 8, N, 1")
SL%B=a,b,c,d	Set serial data port parameters. a= 38400, 19200, 9600, 4800, 2400 or 1200 (baud rate) b= 8 (character length) c= N, O or E (parity) d= 1 or 2 (number of stop bits)

### 12.1.4 Memory related SL commands

Command	Effect and description of command
SL**>	Save current settings as permanent settings
SL*R>	Restore settings to their factory set values
SLSOS	Save current settings as permanent settings

### 12.1.5 Operation mode

Command	Effect and description of command
SL%P=1	Activate Programming menu (baud rate remains) Response: Programming menu
SL++?	Get status of transmission control Response: "0" = Transmission enabled or "1" = Transmission disabled
SL+++	Disable transmission
SL++O	Enable transmission
SL+S=1	Activate sleep mode Response: Modem switches to sleep mode

### 12.1.6 Modem info related SL commands

Command	Effect and description of command
SL!H?	Get radio HW info Response: Board name
SL!V?	Get modem "type" Response: Product variant info
SL%1?	Get arbitrary data stored in memory location 1
SL%1="data"	Set arbitrary data (max 25 characters) in memory location 1
SL%2?	Get arbitrary data stored in memory location 2
SL%2="data"	Set arbitrary data (max 25 characters) in memory location 2
SL%3?	Get arbitrary data stored in memory location 3
SL%3="data"	Set arbitrary data (max 25 characters) in memory location 3
SL%4?	Get arbitrary data stored in memory location 4
SL%4="data"	Set arbitrary data (max 25 characters) in memory location 4
SL%C?	Get product number (or other customer info) Response: Depends on setup
SL%C="text string"	Sets p/n (or other customer info) if it is empty (command works only once) P/n must be stored to eeprom with command SL**> (Save settings) Otherwise it will be lost when power is turned off
SL%D?	Get Modem Type Response: "EASy"
SL%H?	Get logic hardware version Response: Assembly info
SL%I?	Get Firmware FlashID Response: Firmware compilation identifier
SL%R?	Get Regional Info Response: Region code number
SL%S?	Get Serial Number
SL%V?	Get firmware revision information Response: For example "V06.16.3.61"

## 12.1.7 Radio frequency related SL commands

Command	Effect and description of command
SL!D?	Get lower limit of frequency band 1 Response: "nnn.nnnnn MHz"
SL!U?	Get upper limit of frequency band 1 Response: "nnn.nnnnn MHz"
SL!W?	Get lower limit of frequency band 2 Response: "nnn.nnnnn MHz"
SL!Y?	Get upper limit of frequency band 2 Response: "nnn.nnnnn MHz"
SL&+=nnnn	Set active frequency nnnn channels above center frequency Frequency = Center frequency + nnnn*Channel spacing Value of nnnn is [0...number of channels/2] For conventional reasons, only 2 or 4 digit inputs are valid
SL&-=nnnn	Set active frequency nnnn channels below center frequency Frequency = Center frequency – nnnn*Channel spacing Value of nnnn is [0...number of channels/2] For conventional reasons, only 2 or 4 digit inputs are valid
SL&C?	Get reference frequency Response: "nnn.nnnnn MHz"
SL&C=nnn.nnnnn	Set reference frequency
SL&D?	Get operational mode of radio. Response: "S" = Single Channel (default) "D" = Dual Channel "R" = Reverse Dual Channel
SL&D=x	Set operational mode of radio. Values of x are: "S" = Single channel: Rx and Tx frequencies are identical. "D" = Dual channel: Rx frequency = Tx Frequency - (lower limit of frequency band1 - lower limit of frequency band 2) "R" = Reverse dual channel: Tx frequency = Rx Frequency - (lower limit of frequency band1 - lower limit of frequency band 2) Command applies only if lower limits of frequency band 1 & 2 match Dual channel operation NOT RECOMMENDED for new systems - firmware variants with separate Rx/Tx frequencies provide better applicability
SL&E?	Get Enabled Channel Widths Response: List of supported Channel widths e.g. "12.5 kHz, 20.0 kHz, 25.0 kHz"
SL&F?	Get active frequency Response: "nnn.nnnnn MHz"
SL&F=nnn.nnnnn	Set active frequency to nnn.nnnnn MHz
SL&FR?	Get Rx frequency Response: "nnn.nnnnn MHz"
SL&FR=nnn.nnnnn	Set Rx frequency to nnn.nnnnn MHz
SL&FT?	Get Tx frequency Response: "nnn.nnnnn MHz"
SL&FT=nnn.nnnnn	Set Tx frequency to nnn.nnnnn MHz

SL&N?	Get active channel calculated from center frequency ( = (active frequency – center frequency)/channel spacing ) Response: decimal number "+nnnn", "-nnnn", "+nn" or "-nn"
SL&W?	Get channel spacing/channel width Response: "25.0 kHz", "12.5 kHz" or "20.0 kHz"
SL&W=xxxx	Set channel spacing. Value of xxxx is: "1250" for 12,5 kHz "2000" for 20 kHz "2500" for 25 kHz Command is supported only by hardware variants with adjustable channel spacing Before using this command, make sure that active frequency matches new channel spacing
SL%F?	Get status of Error correction (FEC) Response: "0" = FEC OFF or "1" = FEC ON
SL%F=x	Set Error correction (FEC). Value of x is: "1" Set FEC ON "0" Set FEC OFF
SL@C?	Get Call sign settings Response: a,b,c followed by Carriage Return character, where: a=CallSignState (0=OFF, 1=ON) b=CallSignInterval (0...255) in minutes c=CallSignId (max 16 alphanumeric characters) Example: "1,5,MYMESSAGE" followed by CarriageReturn character
SL@C=a,b,c	Set Call sign settings. a=CallSignState (0=OFF, 1=ON) b=CallSignInterval (1...30) in minutes c=CallSignId (max 16 alphanumeric characters)
SL@D?	Get Tx delay (ms) Response: For example "0 ms" or "50 ms"
SL@D=n	Set Tx delay (ms), n is [0...65535]
SL@E?	Get supported radio compatibility modes. Response: List of numbers, separated by commas, showing the supported modes: 0=Satel3AS, 1=PacCrest 4FSK, 2=PacCrest GMSK, 3=Trimtalk GMSK (RX fits PacCrest modems), 4=TrimTalk GMSK (RX fits Trimble modems), 5=PacCrest-FST For example: "0,1" indicates that the modem supports Satel3AS and PacCrest 4FSK protocols.
SL@F?	Get noise level of radio channel Response: "-xxx dBm"
SL@M?	Get repeater function Response: "0" = Repeater OFF or "1" = Repeater ON
SL@M=x	Set repeater function. Values of x are: "0" = Repeater function OFF "R" = Repeater function ON
SL@P?	Get transmitter output power Response: For example "50mW", "1000 mW"

SL@P=nnnn	Set RF output power (mW) For example "SL@P=100" sets 100 mW transmitter output power. Output power is rounded if given value does not match preset power levels. Apart from other compilations, VAR2 accepts only "SL@P=#n" format command, where n is [1...7] the number of the memory location in other words the wanted power level of the transmitter output.
SL@R?	Get RSSI (Received Signal Strength Indication) of last received message (dBm)
SL@S?	Get radio compatibility mode
SL@S=x	Set radio compatibility mode. Value of x is: 0 = Satel 3AS 1 = Option 1 (PacCrest 4-FSK) 2 = Option 2 (PacCrest GMSK) 3 = Option 3 (TrimTalk GMSK) (Rx fits PacCrest modems) 4 = Option 4 (Trimtalk GMSK) (Rx fits Trimble modems) 5 = PacCrest-FST
SL@T?	Get current signal threshold (dBm) Response: "-nnn dBm" (for example "-80 dBm" or "-112 dBm")
SL@T=-nnn	Set minimum power level of signal to be received (=Signal Threshold level) Value of nnn is decimal value [80...118] in dBm

### 12.1.8 Other SL commands

Command	Effect and description of command
SL@X=n	Reset command. Values of n are: "1" Reset BT (applies only to 3AS-OEM11) "9" Reset modem Response: "OK" or "ERROR", then modem resets required blocks.
SL+P=xxxx	Get measured signal strength from remote modem i.e. SL "ping" Value of xxxx [0000...ffff] defines address of remote modem Response: "OK" followed by RSSI info from remote modem
SL+T?	Get status of Transmitter tests Response: "0" = Transmitter tests are OFF "1" = Carrier test is ON "2" = Deviation test is ON
SL+T=x	Activate/Stop transmitter test. "0" = Stop any transmitter test "1" = Transmit Carrier test "2" = Transmit Deviation test
SL+W=xxx,n	Set transmitter output power level xxx [000...255] in memory location n [1...7] 0 sets the maximum power and 255 sets the minimum power

## 13 CHANNEL LIST

A list of predefined radio channels can be stored in the memory in order to change the radio settings simply by switching between the channels. Each channel carries the following info:

- Channel number (any number -32767...32767)
- Transmitter/Receiver frequency
- Channel width (12.5, 20 or 25 kHz)
- Transmitter power level (optional)

Additionally, the default channel that the radio modem uses after a reset is defined.

Channel lists can be created and utilized by using either SATEL Configuration Manager Software or SL commands.

SATEL Configuration Manager software provide a channel list editor (snapshot below) for creating and saving a channel list in the radio modem, or in a file for later usage.

The screenshot shows a software window titled "Channel Selector" with a "Default Channel Set" header. Below the header is a toolbar with buttons: Clear, Load, Save, Add, Edit, Up, Down, Set default, Delete, and Close. The main area contains a table with the following data:

#	User Channel	Frequency	Channel Width	Tx Power
1	0	430000000	12500	1000
2	-5	438000000	12500	100
3	123	468200000	25000	500
4	12345	430000000	12500	200

SL commands provide an interface for a host device to command the radio modem directly. An example of the procedure for creating or replacing a channel list:

1. Clear existing channel list (SL\$C=0)
2. Set channel info for each of the channels to be created starting from index 0 (SL\$L=)
3. Set number of channels in channel list (SL\$C=)
4. Set the default channel (SL\$D=)
5. Verify the new configuration:
  - Get number of channels in channel list (SL\$C?)
  - Get channel info for each of the channels (SL\$L?)
  - Get the default channel (SL\$D?)
7. Enable Channel list (SL\$M=1) in order to activate the Channel list
8. Save the settings (SL\*\*>)

*Note.* "SURV" firmware variants of SATELLINE-EASy radio modems equipped with LCD display provide an easy-to-use channel selection on LCD by using push buttons.

## 14 REPEATER MODE AND ADDRESSING

Repeaters and addressing may be used to extend the coverage area of a radio modem network, and to direct messages to selected radio modems in the network. In large systems, with several repeaters and formed repeater chains, it is often practical to use routing instead of plain addresses.

### 14.1 Repeater

In circumstances where it is necessary to extend the coverage area of a radio modem network, modem can be used as repeater stations.

The maximum size of a repeated data packet is 1 kB (kilobyte). The Repeater Function is switched on using the Programming Mode. In the repeater mode the radio modem will function as a totally independent unit, which means that only a power supply and a suitable antenna are needed. Other devices are not necessary.

A radio modem acting as a repeater can also be used to receive and transmit data. In repeater mode the radio modem will transmit the received data to the serial interface in a normal fashion. The difference being that the received data will be buffered into the buffer memory. After reception the radio modem will re-transmit the buffered data using the same radio channel as in reception. Data received through the serial interface a radio modem in repeater mode will transmit normally.

The same network may include several repeaters, which operate under the same base station. Repeaters may also be chained; in which case a message is transmitted through several repeaters. In systems with more than one serially or parallelly chained repeater, addressing or routing protocol must be used to prevent a message ending up in a loop formed by repeaters, and to ensure that the message finally reaches only the intended radio modem.

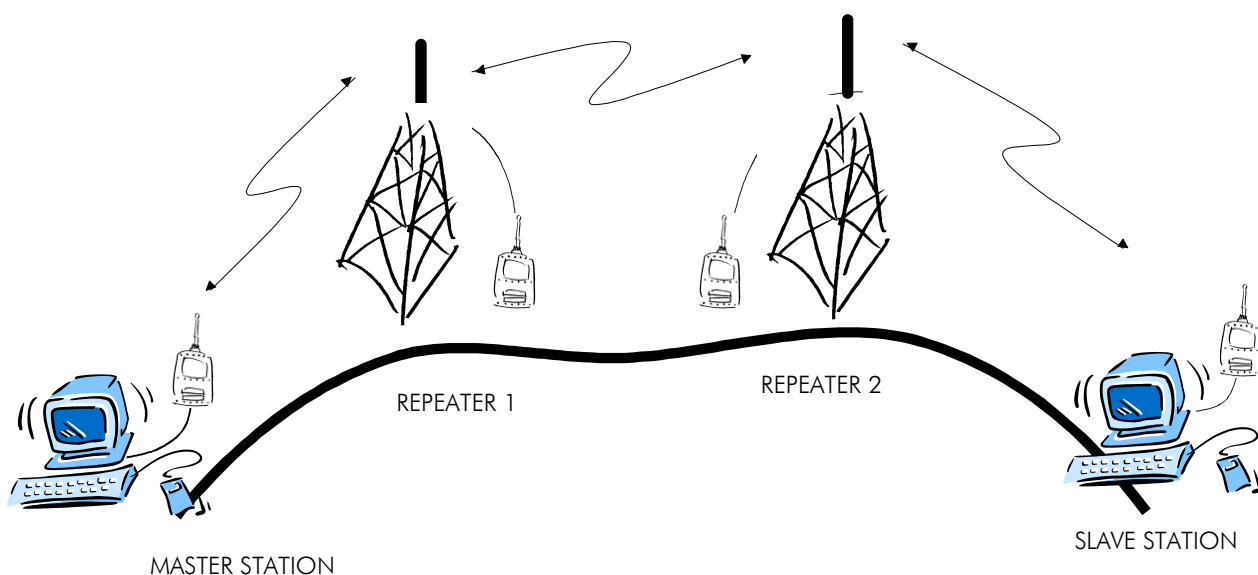

## 14.2 Addressing

Addresses can be used to route a data message to the desired destination or to separate two parallel networks from each other. In networks with repeaters it is usually necessary to use addresses to prevent data messages from ending up in loops formed by repeaters. In case of setting the "Message Routing" function in use, Tx / Rx addresses are ignored by the modem.

Modem allows the use of individual addresses both for reception and transmission. Addresses can be switched on separately, or simultaneously, in both data transfer directions.

The radio modem contains two transmission and two reception addresses, which are known as the primary address and secondary address. The primary address is used whenever data from the serial interface is transmitted. At the receiving end, the radio modem will receive using either of the two receive addresses.

### **Secondary transmit address is only used in repeater applications.**

Radio modems configured to function as repeaters, will repeat data messages using either the primary or secondary address, depending upon which address was used during the reception of the data message.

If only one address pair is needed in a network, both addresses must be set the same (TX1 = TX2 and RX1 = RX2).

It is also possible to transfer the received address onto the serial interface.

The address is composed of two characters totalling 16 bits, resulting in over 65,000 different address combinations. The address is attached to the beginning of each data packet sent by the radio modem. When a radio modem receives a data packet whilst using addressing mode, the radio modem will check the first two characters of each received data packet to ensure that the packet in question was intended for the correct radio modem.



Address may be selected between 0000h...FFFFh (h = hexadecimal, corresponding decimal numbers are 0-65535).

Example: address 1234h (4660 in decimal format), where 12h is ADD H and 34h is ADD L.

Example: address ABFFh (44031 in decimal format), where ABh is ADD H and FFh is ADD L.

### Transmission:

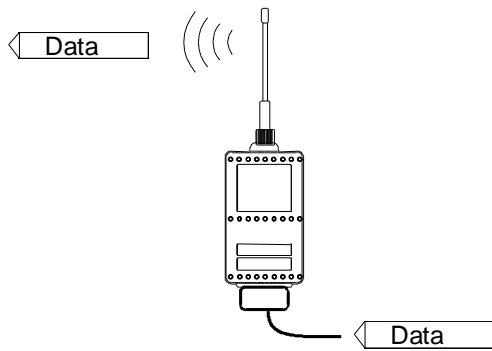

Transmission address has been set OFF.  
Radio modem will transmit the data  
packet as such.

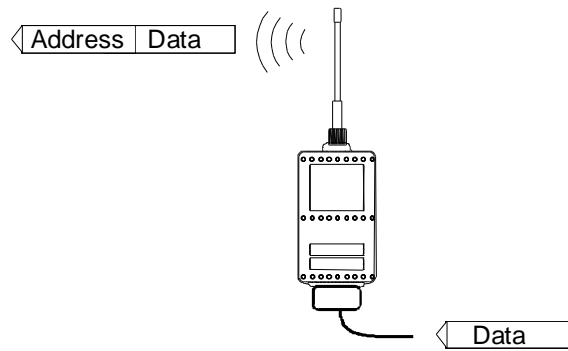

Transmission addressing has been set  
ON. The radio modem will add the  
primary TX address to the beginning of the  
data packet.

### Reception:

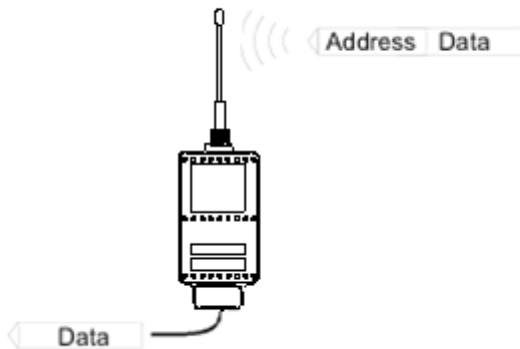

Reception addressing has been set ON  
and either the primary or secondary RX  
address of the radio modem is identical to  
the address of the received data packet.

The radio modem will remove the address  
and send the actual data to the RS-232  
interface.

However, if the "RX Address to RD-line"  
setting is on, the radio modem does not  
remove the address.

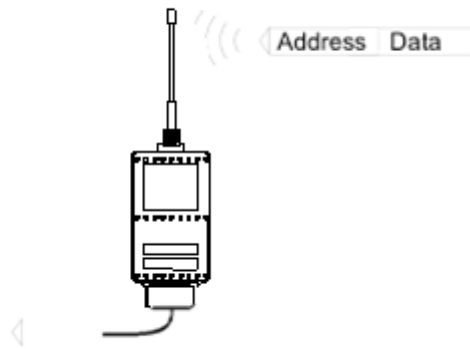

Reception addressing has been set ON,  
but both the primary and secondary RX  
addresses of the radio modem are  
different from the address of the received  
data packet.

Data does not appear on the RS-232 -  
interface.

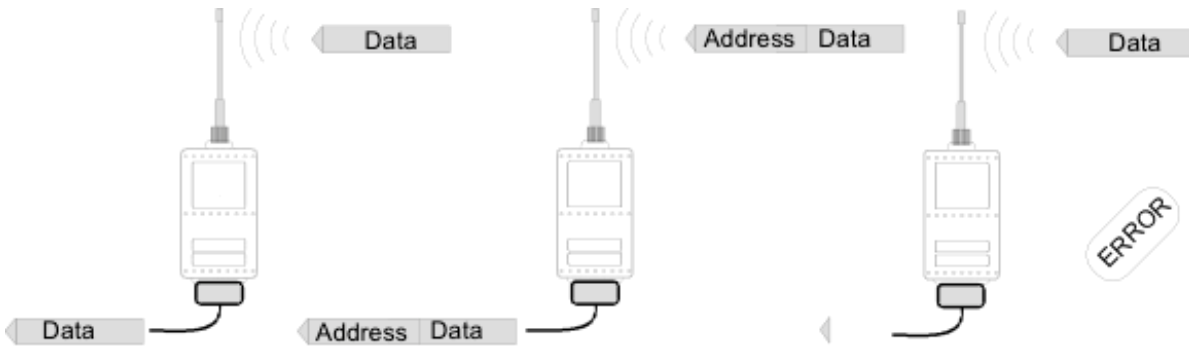

Reception addressing has been set OFF.

The radio modem will transfer all received data to the RS-232 - interface.

Reception addressing has been set OFF.

The radio modem will consider the characters of the address as a part of the data and will send all the characters to the RS-232 interface.

Reception addressing has been set ON but there is no address in the data packet.

Data will appear on the RS-232 interface ONLY if the first 2 characters of the data match either of its own RX address. The radio modem will remove those 2 characters of data.

### 14.2.1 Connection between two points

When forming a connection between two points it is recommended that both the reception and transmission addresses are identical in both radio modems. This is the easiest way to control addresses and the risk caused by interference from other systems operating in the same area is minimal.

Example: by setting all addresses of both radio modems to a value '1234', they will accept only those messages which contain this address, and they will use this same value when transmitting data.

If the channel is reserved for use only by the single network, or if the terminal devices are responsible for addressing, it is not necessary to use addressing in the radio modems.

### 14.2.2 System of one base station and several substations

In systems with several substations, the base station must know to which substation each message is intended, and from which substation each received message originates. Usually terminal devices handle addressing completely, but it is also possible to use the addressing functionality of the radio modems.

For example, if the substation terminal devices are not able to check and form addresses by themselves, addressing may be achieved with the help of the addresses of the radio modems attached to these terminal devices. The base station may, in such a case, define the destination of a message by adding the address of the corresponding radio modem into the beginning of the data packet. The substation radio modem(s) will check the address and the corresponding radio modem will identify and remove the address characters. In a similar way, the substation will add when transmitting to the base station its address characters into the beginning of the data packet, thus defining the origin of the sent data packet. In the base station radio modem, addresses have been switched OFF, so that they are transmitted as is to the base station terminal device for further processing.

### **14.3 Using repeaters and addresses in the same system**

In systems with several repeaters, a substation and a base-station, addresses must be used in radio modems. It is possible to realise also a system with only one repeater without addressing. In such a case, the base station will however hear the message both from the substation and from the repeater, in other words the message is duplicated as it moves along the route.

There are at least two ways of realising such a system depending on the capabilities of the terminal devices in question and on the number of repeaters to be used and on their relative positions to each other.

#### **14.3.1 System with several repeaters**

In systems with several serial or parallel-chained repeaters, addressing must be used to prevent messages from ending up in loops otherwise formed by repeaters, and to ensure that only the desired (addressed) radio modem receives the data intended for it.

All radio modems in the network must be set to a state, in which the RX-addressing is switched ON and TX-addressing is switched OFF. Base-station and all substations add an address string in the beginning of the data to be transmitted. In the relaying of the message addressing is used in the following way:

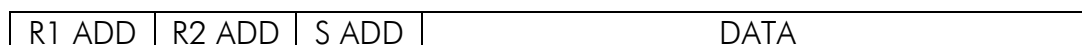

- The above is the data received from the base station terminal device, containing repeater addresses (R1 ADD, R2 ADD) and the substation address (S ADD). Two characters define each address.

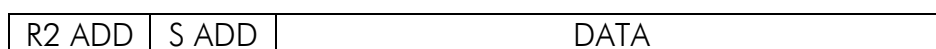

- The above is the same message after being relayed from repeater 1 to repeater 2.

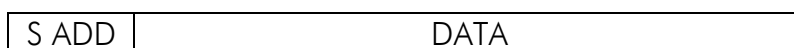

- The above is the same message after being relayed from the last repeater in the chain (repeater 2) to the substation.



- The above is the same message being relayed via the serial interface of the substation radio modem to the terminal device.

In a situation where the substation transmits data towards the base-station the address is formed in a similar way, but the order of the addresses is reversed:

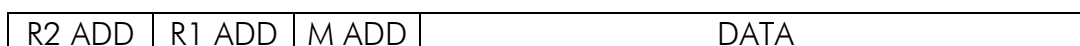

-In the above, R2 ADD is address of repeater 2, R1 ADD is address of repeater 1 and M ADD is the address of the base-station.

### **14.3.2 Repeater chain using address pairs**

In a situation where the terminal devices and substations cannot form address fields, but are able to recognise messages addressed to them, alternating address pairs may be used. Transmit address (TX) and receive address (RX) alternate in the order shown in the table below.

Address type	Base-station address	Repeater 1 and the addresses of the substations of the base-station	Repeater 1 substations addresses
TX-address	Address 1	Address 2	Address 1
RX-address	Address 2	Address 1	Address 2

In a network where alternating addresses are utilised, the exact route that is used to relay a message to a certain radio modem is fixed at the time of installation and configuring the system. The order of the addresses must be the same as the order of the route that is used to relay the message to the radio modem. It should be noted however, that in networks where alternating addresses are used the base-station and substations will hear their own messages repeated.



## 15 MESSAGE ROUTING

### 15.1 Introduction to Message Routing,

*Message Routing* is an exciting feature in radio modem. This feature allows messages from terminal devices to be automatically routed over the radio modem network to a specified recipient terminal.

In brief, the *Message Routing* works as follows:

- First, a radio modem reads any message coming from the terminal(s) attached to it.
- The radio modem detects the terminal address of the recipient, by seeking a pre-set position inside the message for the address.
- The radio modem checks its internal route table to see, if there is route information corresponding the address it has just found.
- The radio modem transmits a radio frame, which includes
  - the network id (see later)
  - the route information
  - the original user message encapsulated
  - redundant information such as checksums for error checking etc.
- The radio modems along the route relay the frame over the network to the radio modem at the destination.
- The radio modem at the destination first checks the validity of the received radio frame, then extracts the original user message, and finally outputs it the terminal device attached to it.

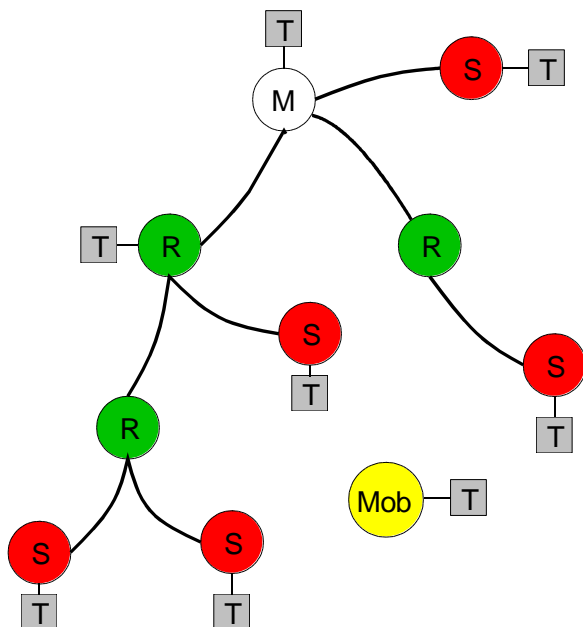

The figure left illustrates a possible structure of a radio modem network.

M = Master station (Central station)

R = Repeater station

S = Slave station

T = Terminal device

Mob = Mobile terminal

Terminals are usually PLC devices that send and receive messages according to a specific user protocol.

*Note:* The term *repeater* used in the context of the *Message Routing* should not be mixed with the *Repeater Mode*, which is a feature independent from the *Message Routing*.

### **15.1.1 Features of Message Routing**

The *Message Routing* feature of the modem is designed to be a fast and transparent to fit real time systems. The features include:

- Transparent to user protocols.
- Easy construction of a network containing several repeaters.
- Any radio modem may operate as a repeater, i.e. dedicated repeaters are not usually needed thus cutting down on costs.
- Large areas of coverage may be implemented by using only one radio channel.
- The use of mobile substations is also possible to some extent.
- The system will be fully deterministic i.e. the transmission delays are predictable. Because of that, the principle of *Message Routing* is connectionless.
- Added redundancy, as a failing radio modem can be, in certain cases, bypassed with another radio modem positioned in the same coverage area.
- *Message Routing* is intended mainly for the protocols based on polling scheme and a single master station.

### **15.1.2 Limitations of Message Routing**

- It is assumed that the position of the address field in the user messages is fixed. However some special protocols are supported:
  - IEC 60870-5-101 is a protocol commonly used in control applications of power lines.
  - RP570 protocol
- The message cannot end to the address; there must be at least one character after the address.
- It is assumed that there is only one message at a time inside the network simultaneous messages could cause collisions.
- The max number of the routes depends on the actual hardware and the Firmware version.
- Operation of the Tx / Rx addresses is automatically blocked in the case of switching the "Message Routing" function on.

### **15.1.3 Getting started with Message Routing**

The design of any radio modem system requires very precise planning. Once the choices between devices, their location, installation, maintenance etc. are clear, the *Message Routing* for the system can be implemented.

Planning your *Message Routing* System

1. Decide which mode of the *Message Routing* suits the system - *Source Mode* or *Virtual Mode*. See the following paragraphs for details.
2. Design a layout of the system describing the settings such as protocol, addresses of the terminal equipment, radio frequencies and so on.
3. Configure the radio modems accordingly. There are two ways to configure the parameters related to the *Message Routing*:

1. SaTerm PC-program
2. Manual configuration in the setup menu.

In either case, please check the chapter on *Settings* before changing the setup of the radio modems.

Finally, when all the radio modems have correct settings, they are ready for further installation.

#### 15.1.4 **SaTerm and the configuration of the Message Routing**

SaTerm is a PC based program that allows the user to design their required network simply and quickly using a graphical interface to literally draw the network plan on the screen.

- Firstly, a picture of the network is created to show all the radio modems and the intended route that the data is to take.
- Secondly, the required settings are defined in the drawing.
- Finally, the setup of each actual radio modem can be uploaded by connecting the actual radio modems one by one to the COM port, switching them to the programming mode, and clicking the transmit button of SaTerm.

Please check the user manual of SaTerm for more details.

The figure below shows a snapshot of a typical routing window taken from SaTerm screen.

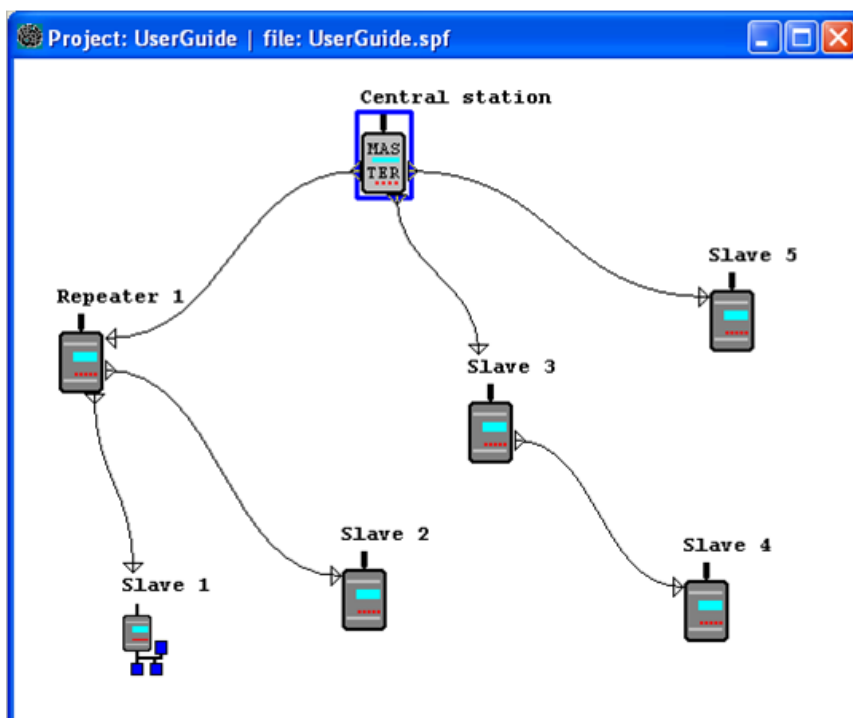

### 15.1.5 Manual configuration of the Message Routing

The radio modems can be configured manually via the programming menu. However, this is recommended only if the structure of the network is very simple, or if it is desirable to define such special functions that are not possible to draw using the graphical interface of *SaTerm*. Examples of such cases are for example non tree-structured networks, or the use of same repeaters in several overlapping networks. The operation of the *Message Routing* must be clearly understood before configuring the radio modems manually.

### 15.1.6 Configuration of the protocol in Message Routing

A radio modem will detect the presence of an address used by inspecting the protocol from the message received via the serial interface. On the basis of this user address, all necessary information needed to relay the message to destination is fetched from an internal routing table inside a radio modem. The user protocol is not interpreted; instead, the user address is searched according to its location in the message. The beginning of the packet is located by a preceding pause in the byte stream. Message Routing can therefore be applied to most protocols with fixed address field position.

The position and length of the address is defined by two settings: *Offset* and *Length*.

- Offset defines the number of bytes (0...15) preceding the address.
- Length is the length of the address in the user protocol expressed in bytes (1...4).

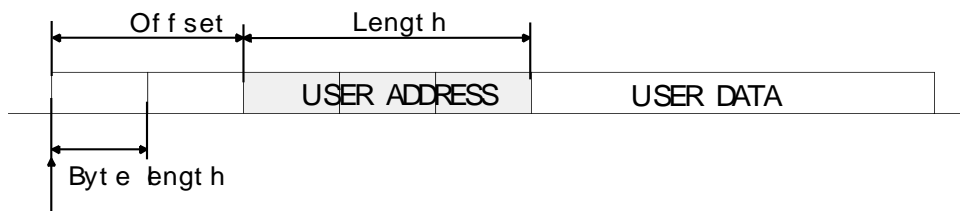

Start of data packet, Offset=2, Length=3

A transmitting radio modem adds a routing header and a tail to the user message. Consequently, a radio modem that receives the message removes the header and tail - so the Message Routing scheme is transparent to the user protocol.

## 15.2 Operating modes of Message Routing

The *Message Routing* has two different operating modes:

- *Source Mode Routing*
- *Virtual Mode Routing*

The most important differences between the two modes are shown in the table below.

Property	Source Mode Routing	Virtual Mode Routing
Summary	Slower, more functions	Faster, less functions
Radio interference tolerance	Yes, overhop function	No
Support for mobile stations	Yes	No
Addition of substations to a network	Only master station needs to be reconfigured	Master station and consecutive repeaters need to be reconfigured
Changing routes	Only master station needs to be reconfigured	All radio modems need to be reconfigured
Maximum length of route	13 hops	No limit
Overhop function	Yes	No
Network ID	Yes	Yes
Storing of routing information	Centralised	Dispersed
Message Routing overhead (bytes)	$10 + 2 * \text{number of hops}$	9
Maximum length of user protocol message (bytes)	1 kB – Message Routing overhead	1 kB – Message Routing overhead

Other issues common to the both modes:

- The maximum number of terminals depends on the radio network structure and the number of routes.
- Multiple terminal addresses may be attached to a radio modem.
- The maximum length of a terminal address (in the user's protocol) is four bytes (FFFFFFFF in hexadecimal).
- The maximum length of the address of a radio modem is two bytes (FFFF in hexadecimal).

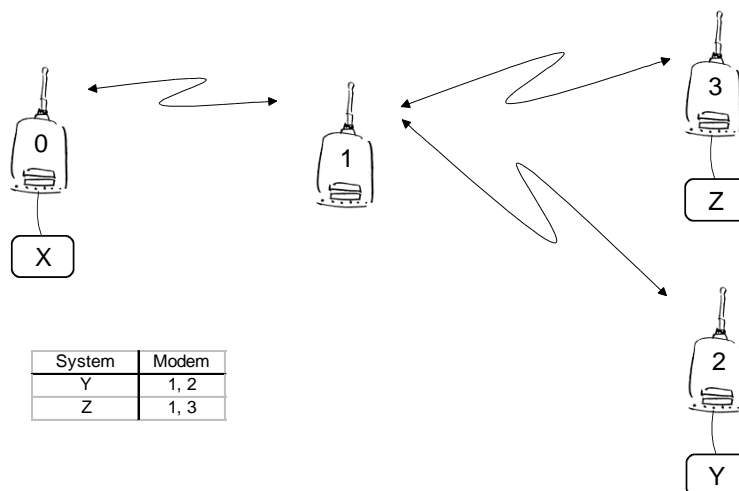

## 15.3 Detailed description of Message Routing

### 15.3.1 Source Mode Routing

The above figure represents a network containing four (4) radio modems. Each radio modem is given a unique address (0...3). A terminal device has been attached to the three of the four radio modems and they communicate with each other using terminal addresses X, Y and Z, respectively. Radio modem 0 and terminal device X together constitute the base station of the network and all routing information of the network has been programmed into this base station.

When the terminal device X transmits a packet to (e.g.) terminal Y, radio modem 0 will detect the address Y from the data received through the serial port. From the routing table a route 1,2 can be found to which the radio modem also adds its own address to define the route for return data. Radio modem 1 repeats the packet and radio modem 2 removes the address information from the received data packet thereby transferring only the original data to the serial interface. The address information received together with the packet is reversed (2, 1, 0) and saved to be used in the transmission of subsequent reply packets.

### 15.3.2 Virtual Mode Routing

Please contact SATEL for more information of Virtual Mode Routing.

### 15.3.3 Overhop function in Source Mode Routing

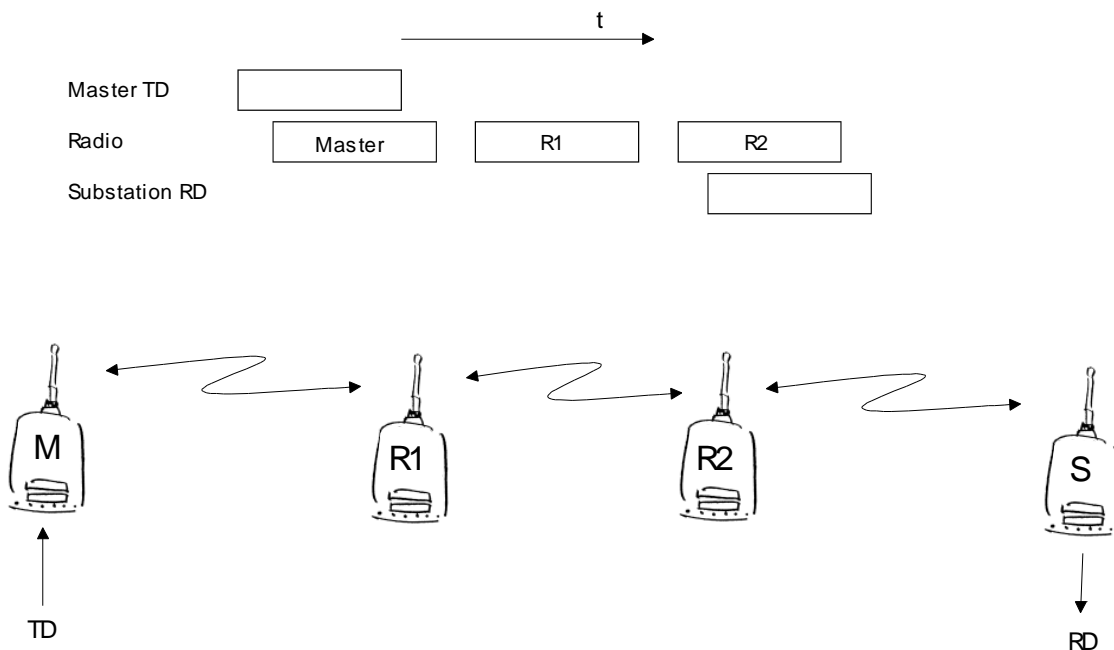

When using repeaters, the same packet is sent via a (radio) channel several times. A radio modem situated in the repeater chain will often hear other radio modems in addition to the immediate neighbouring radio modems. With *Source Mode Routing* the complete address information is sent

together with the packets enabling the use of these secondary routes. Usually repeaters have better antennas (and/or antennas placed higher) than normal substations, which means that the distance between two repeaters can be much longer than the distance between a repeater and a substation.

Connections to other than the neighbouring stations of the repeater are not necessarily reliable under all possible (radio) conditions, but they can often be used to keep the network up and running at least partially should a repeater somewhere in the middle of the chain fail. In addition to this, the likelihood of a transmission error decreases if it is possible to listen to more than one transmission since; in this case, it is more likely that at least one of them will be received error-free. It is also possible, that the radio connection is asymmetrical due to the greater output power of a repeater or due to local interference, in which case, data can in fact travel in opposite directions using different routes.

When a repeater receives a message that contains its address but not as the first address in the address field, the packet is stored in a buffer. If the relayed message from the repeater, and the modem having sent the message originally, is not received (due for example, because of radio modem failure or if it has an erroneous checksum), the packet already buffered into the memory is re-sent without any change to the timing (no additional delays are introduced). Because of this, relatively short hop distances can be used, without the likelihood of errors being increasing due to the added number of repeats. A possible error in one of the repeaters does not necessarily cause a total breakdown of traffic.

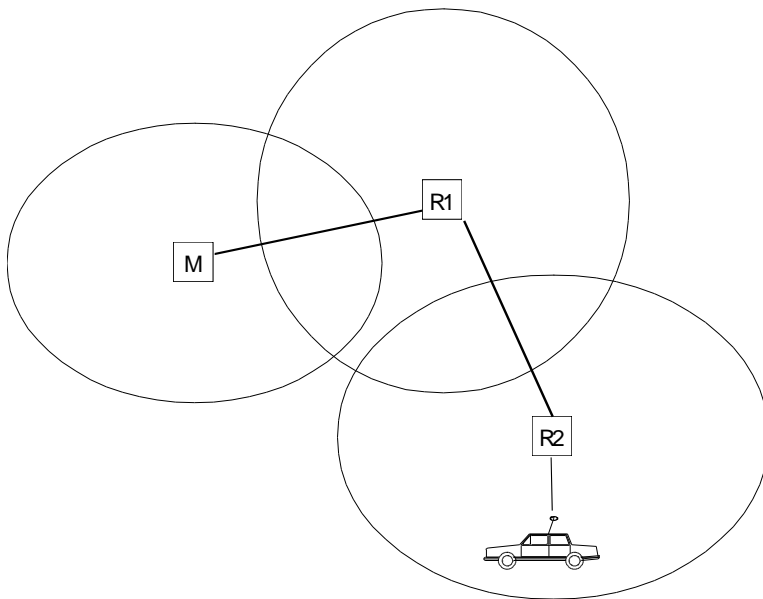

The overhop function allows for the use of mobile substations. In the example above, a mobile substation is first located in the coverage area of repeater R2. The route is defined as M, R1, R2 and vehicle. When the vehicle moves to the coverage area of repeater R1, the radio modem picks the packet already from the transmission of R1. This is then transferred to the serial port using an additional delay, so that the timing does not differ from the first situation where the radio modem of the vehicle was in the coverage area of repeater R2. In this way a collision of the reply transmission and the transmission by repeater R2 is prevented. When the mobile station is transmitting, it is enough that at least one radio modem defined to be a part of the route receives the transmission.

#### **15.3.4      Network ID**

The Network ID is a string of up to eight characters, which is used to prevent the reception of the messages coming from an external system. The radio modems operating in the same system using *Message Routing* must have the same Network ID. Only the messages that have a matching Network ID are received.

## 16 INSTALLATION

### 16.1 Installation of the radio modem

The radio modem should be installed with the installation accessories supplied with the radio modem. There is also available an installation component for mounting the radio modem to a DIN-rail.

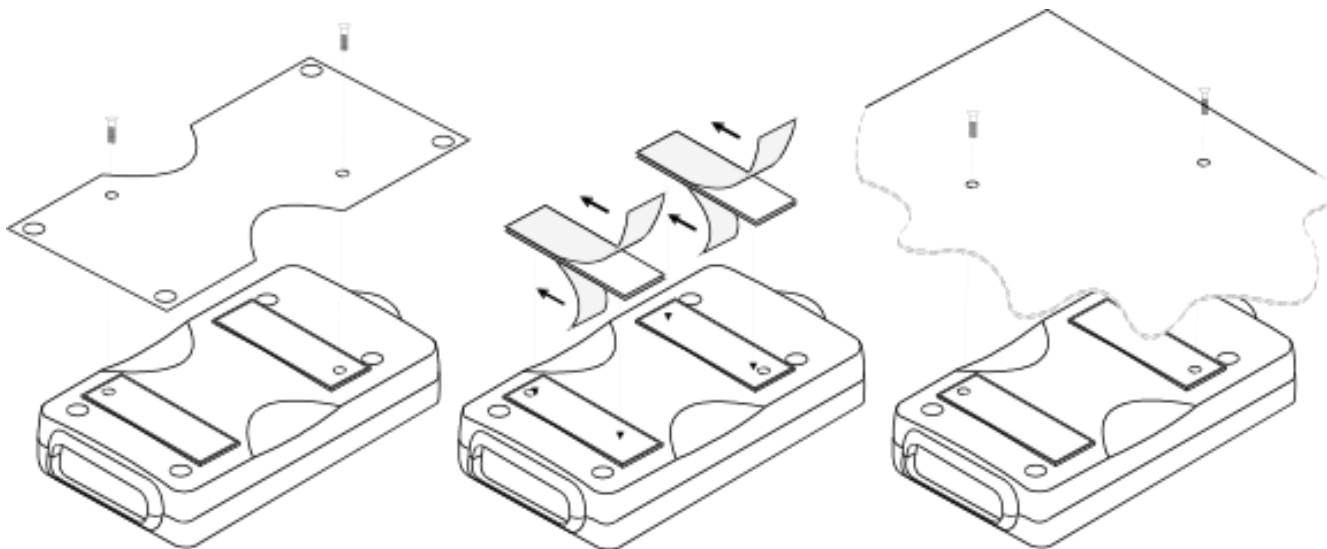

1. Installation with the installation plate supplied with the radio modem. The installation plate is fastened to the backside of the radio modem.

The installation plate can be mounted using the holes provided on the plate.

2. Installation using the Velcro-tape provided with the radio modem.

3. Installation can also be made directly to customer's equipment.

#### **NOTE!**

When selecting a suitable location for the radio modem it must be ensured that no water can get into the radio modem under any conditions. Direct sunlight is also to be avoided. It is not recommendable to install the radio modem on a strongly vibrating surface. Suitable dampening and/or isolation materials should be used in cases where the installation surface will be subjected to vibration.

## 16.2 Wiring

**NOTE!**  
When installing the cables of the serial interface, the operating voltage of all devices must be off (POWER OFF condition).

### 16.2.1 RS-232 wiring - Port1 without handshaking

The simplest connection to PC serial port (RS-232) is depicted in the schematic below.

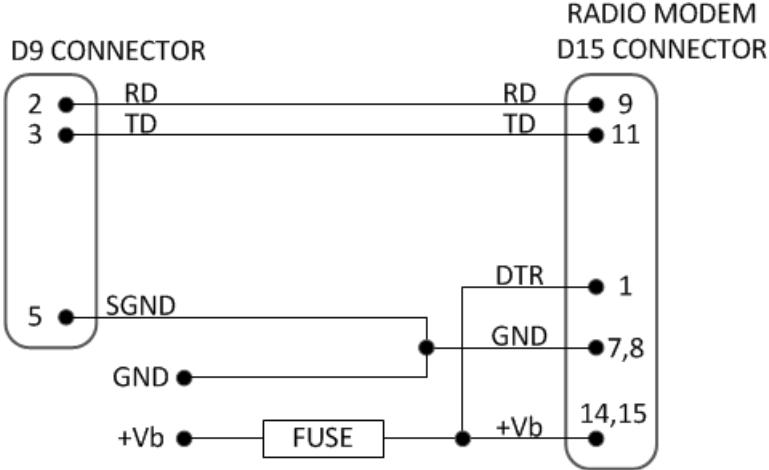

FUSE = 1 A slow (+6 ... +30 V assembly) or 2.5 A slow (+3 ... +9 V assembly)

**16.2.2 RS-232 wiring - Port1 and handshaking signals connected**

A typical connection between the Port 1 of the radio modem and the PC serial port (RS-232) using the handshaking signals is depicted in the schematic below.

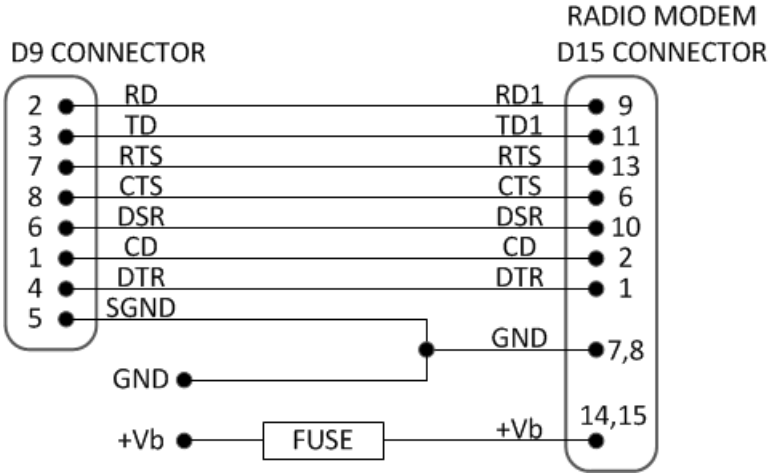

FUSE = 1 A slow (+6 ... +30 V assembly) or 2.5 A slow (+3 ... +9 V assembly)

**16.2.3 RS-422 wiring**

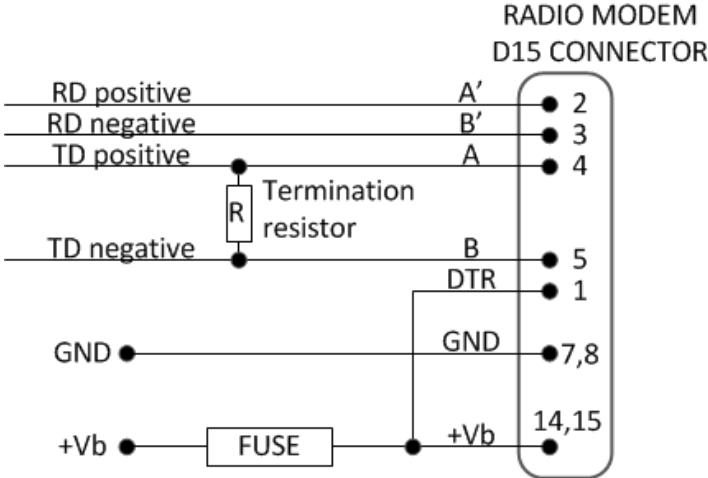

FUSE = 1 A slow (+6 ... +30 V assembly) or 2.5 A slow (+3 ... +9 V assembly)

If the transmission lines are long the receiving end of the lines must be terminated using a separate termination resistor (typical values range from 100 -120 ohm depending on the characteristic impedance of the transmission line).

### 16.2.4 RS-485 wiring

Both ends of the transmission line should be terminated by connecting a separate terminating resistor between the positive and negative signal wire. Typical values range from 100 – 120 ohm depending on the characteristic impedance of the line.

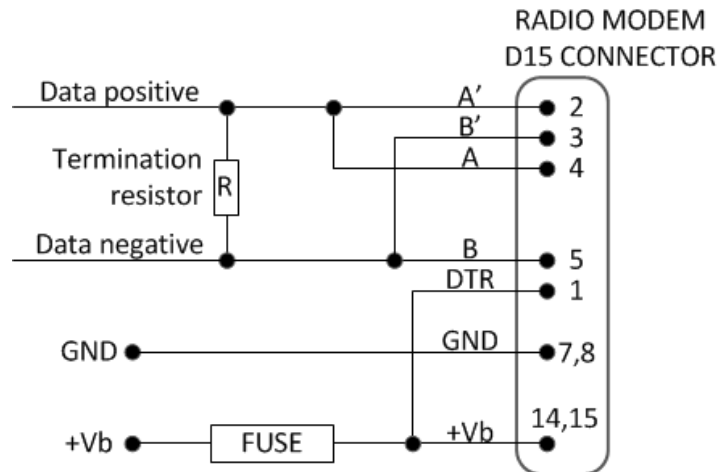

FUSE = 1 A slow (+6 ... +30 V assembly) or 2.5 A slow (+3 ... +9 V assembly)

**NOTE!** The RS-485/422 standards define only the electrical parameters of the signals (signal level etc.). The connectors and the names of the signals are NOT defined. Different RS-485/422 standards or proprietary buses specify different names for the wires. Common signal names used are 'A' and 'B', '+' and '-' or 'hot' and 'cold'. Unfortunately these names define the polarity of the signals only for a specific system or specific equipment. In reality 'A' of one system can actually be 'B' of another. If the polarity is wrong, the data will be inverted. Usually the simplest way to solve the issue is the trial and error method, as RS-485 signals can be connected only two ways.

**16.2.5 Programming mode adapter**

The wiring below is for configuring the radio modem via the Programming mode menu.

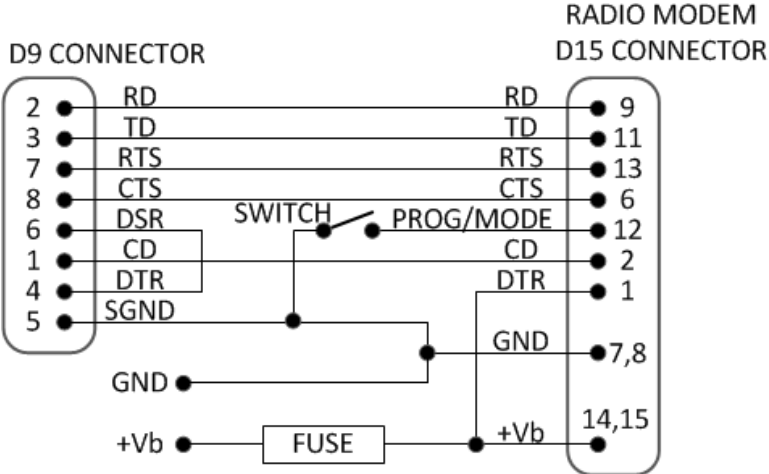

FUSE = 1 A slow (+6 ... +30 V assembly) or 2.5 A slow (+3 ... +9 V assembly)  
 SWITCH = Programming mode switch (ON=Programming mode, OFF=Data transfer mode)

## **16.3 Antenna installation**

### **16.3.1 Hand-held equipment**

- ¼-wave antenna (wavelength at frequency of 450 MHz is approximately 70 cm)
- Helix-antenna

Antennas are installed directly to the TNC connector at the upper part of the radio modem.

### **16.3.2 Mobile equipment**

- ¼-wave antenna
- ½-wave antenna

The ideal installation position is vertical, and there should be at least 0.5 m of free space around the antenna. A separate ground plane should be placed under the ¼-wave antenna (vehicle rooftop or the engine hood or trunk door are usually suitable). In problematic cases the most suitable type is a ½-wave antenna. It can be installed directly at the top of a pipe with the added benefit of gaining as much as free space around the antenna as possible. In case the antenna cannot be directly connected to the radio modem, a coaxial cable with 50 ohm impedance must be used between the antenna and the antenna connector.

### **16.3.3 Base stations**

- Omni-directional antennas (¼-, ½- or 5/8-wave antenna)
- Directional antennas (yagi /multi-element antenna or corner antenna)

The antenna should be installed in a vertical position. The exact location of the antenna depends on several factors, such as the size of the overall system and the coverage area terrain contours. A rule of thumb is that the base station antenna should be located at the highest point of the coverage area and as close to the centre of the coverage area as possible. The base station antenna can also be located inside a building, if the walls of the building do not contain metal.

### **16.3.4 General antenna installation instructions**

The reliability and the achievable coverage of useful signal strength can be severely affected by the positioning of the antenna. Antenna and cable connectors should have gold-plated pins and sockets, as use of low quality connectors can lead to eventual oxidation of the connector surfaces, which in turn may degrade the contact and cause additional attenuation. Good quality tools and materials must be used when installing radio modems, antennas and cables. The weather tolerance of the materials used must also be taken into account. Installed materials must withstand all foreseeable weather conditions (frost, excess sun, direct UV-radiation, seawater etc.). Also possible environmental pollution must be considered (acids, ozone etc.).

Antennas must be installed well away from metallic objects. In the case of small antennas this distance should be at least ½ m. With large antennas the distance should be >5 m and in case of repeater antenna combinations >10 m.

If the system contains a large number of radio modems, the best location for an antenna is the highest point of a building and possibly an additional antenna mast. If a separate antenna mast is used, the antenna can, if necessary, be installed sideways about 2...3 m from the mast itself.

When installing an antenna possible interference sources must be considered. Such interference sources are, for example:

- mobile telephone network base station antennas
- public telephone network base station antennas
- television broadcast antennas
- radio relay antennas
- other radio modem systems
- PC-related devices (approximately 5 m radius from antenna)

Please note that antennas are always tuned to a specific frequency range when ordering them. Simple antennas and antennas, which have been constructed of stacked yagi-antennas, are typically rather broadband. As the number of yagi-elements increases the frequency range becomes narrower.

When designing and installing a system it is advisable to prepare to test the system, and also to consider serviceability of the system. In particular cabling should be planned to allow easy access and to allow for maintenance. It is often practical to use long antenna cables, so that the radio modem can be installed far enough from the antenna itself to a location that is easily accessible.

The type of the antenna cable is dependent on the length of the antenna cable, and the following table can be used to select a suitable type:

Length	Type	Attenuation 10m/450MHz
<5m	RG58	3.0dB
0...20m	RG213	1.6dB
>20m	ECOFLEX10	0.9dB
>20m	AIRCOM+	0.8dB*
>20m	ECOFLEX15	0.6dB
*) AIRCOM+ cable is partially air insulated, so the use of this cable requires that the connection between the cable and the connectors are fully airtight.		

If there is a line-of-sight path between the antennas a 6 dB power marginal is usually adequate. However, if the connection is built on the reflection and/or the knife-edge diffraction the path loss can vary even 20 dB depending on the weather conditions. In this case a short test can give a too positive result of the quality of the connection. Thus the height of the antennas and topographical obstacles must be surveyed with great care. From time to time a marginal connection can be used if the data transmission protocol is well prepared for this and the data transmission that occasionally slows down does not cause any problems to the system.

Vertical polarised antennas (antenna elements are in vertical position) are often used in radio systems. In a system between a base station and substations vertical polarisation is recommended. The radio modem antenna cannot be mounted on the same level as the other substation antennas in the same building. The best way to distinguish from the other antennas situated in the neighbourhood is to mount the antennas as far as possible from each other on the altitude level. The best result is generally obtained when all the antennas are in the same mast. With an extra ground plane between the antennas more distinction can be obtained between the antennas in the mast.

Horizontal polarisation can be used in data transmission between two points. With the polarisation attenuation more distinction is obtained to vertical polarised systems. The influence of the directional patterns of the antennas must, however, be taken into consideration. If a distinction to another interfering antenna is wanted with the horizontal polarised antennas there must be a good attenuation of the back lobe. In addition to this the interfering radiator should be situated behind the antenna.

When a system does not demand the use of an omni-directional antenna it is recommended that directional antennas are used e.g. two-element yagis in permanent external installations. Please note that as antenna amplification increases the setting of the direction of the antenna requires more attention.

Base stations in high places should be supplied with high-Q cavity filters. Please note that the higher the base station antenna, the larger the coverage area and in turn that the risk of interference is also increased.

SATEL recommends the use of a band-pass filter with a large Q in the antenna cable of the base station.

**Example of an antenna installation:** Long connection distances can be realised by using amplifying antennas ( $G=Gain$ ) and by installing the antenna high.

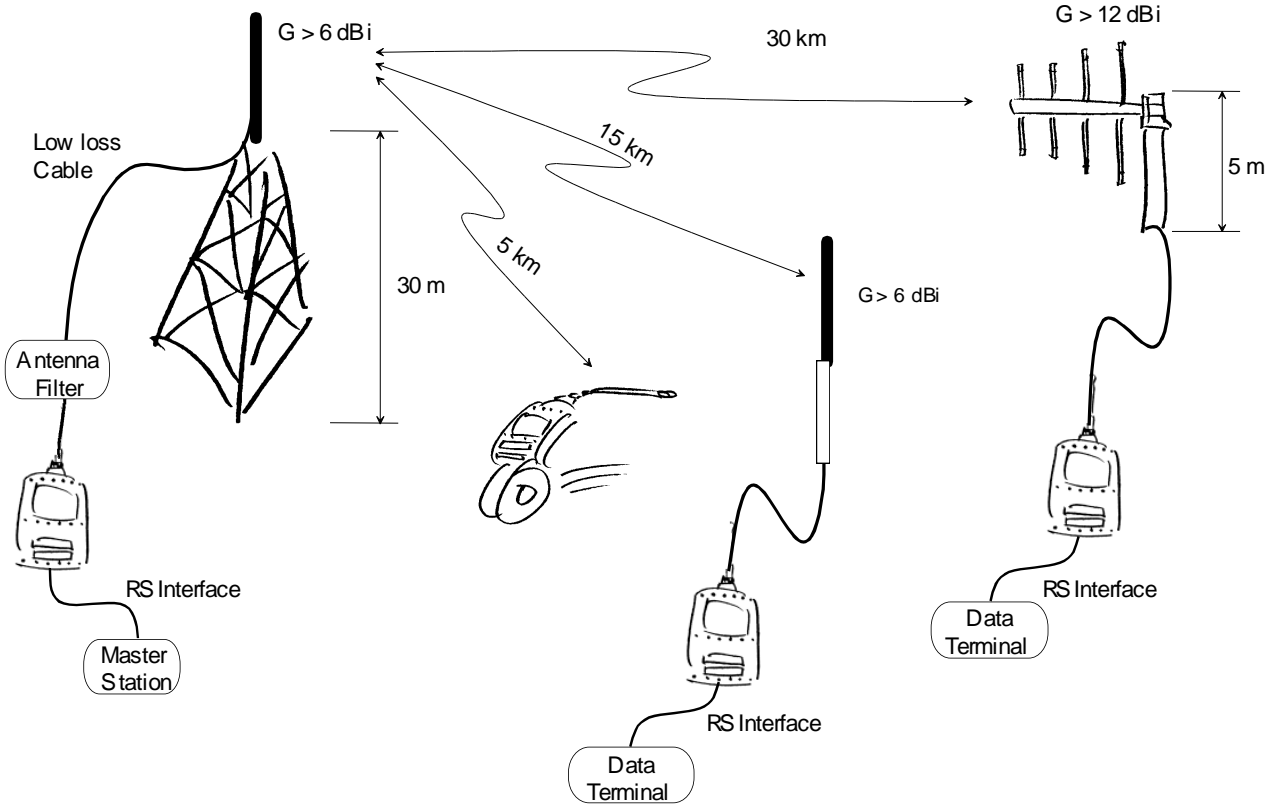

## 17 DESIGNING SYSTEMS

### **17.1 Factors affecting the quality and distance of the radio connection**

- power of the radio transmitter
- sensitivity of the radio receiver
- tolerance of spurious radiation's of the radio modulating signal
- amplification of transmitting and receiving antennas
- antenna cable attenuation
- antenna height
- natural obstacles
- interference caused by other electrical equipment

The transmitter power of the modems using 403 – 473 MHz frequency range is 1 W (maximum) and the sensitivity of the receiver better than -115 dBm. Thus in a flat area and in free space with a 1/4 wave antenna (antenna amplification 1dBi) and antenna height of 1 m communication distances of 3 to 4 km can be achieved. Distances may be considerably shorter in situations where there are metallic walls or other material inhibiting the propagation of radio waves.

Over long distances, increasing the height of antennas can often solve problems caused by natural obstacles. A ten-fold increase in distance can be achieved with the use of amplifying antennas. Frequent topographical variations over long distances may require that at least one of the antennas be raised to a height of 10 to 20 m.

If the antenna cable is more than 10 meters long it is necessary to use a low loss cable (< 0.7 dB /10 m) in order not to waste the antenna amplification. Adding a repeater station can also solve problematical radio connections. In systems with many base stations the RSSI-signal can be used to assist in choosing the base station with the best signal. A communications network can also be built with a combination of cables and radio data modems.

Modem tolerates normal levels of interference that occur. However, exceptionally high levels of interference can break through the safeguards and thus cause errors in data transfer. In mobile vehicle applications the range of operation can be increased by dividing the transmitted data into e.g. 50...500 byte long blocks and by re-transmitting the defected blocks.

A sufficient safety margin can be obtained by testing the communication path using extra 6 dB attenuation at the antenna connection and with slightly less effective antennas than those to be used in the final system.

## **17.2 Radio field strength**

Radio signal strength must be good enough for successful data transfer. Where field strength is above a certain level, the operational results are very good. Below this level, a few dB marginal areas occur in which errors begin to be generated by noise and interference that will eventually lead to loss of connection.

The field strength is at its optimum level in open space, although increasing distance will still reduce it. It must also be remembered that one open space has different environmental and external factors to another, and that the effects on transmission quality must be taken into account when planning the system.

Ground, ground contours and buildings cause attenuation (loss of energy through absorption) and reflection of radio waves. Buildings reflect radio waves and therefore the effects of attenuation are not as acute when transmission is over a short distance.

However, the reflected waves will often be a bit delayed, and when they combine with the direct radio waves they interact in either a weakening or a strengthening way. This causes the fading effect in mobile systems. In reality very sharp signal drops spaced about 35 cm apart may occur. The attenuation may even reach 40 dB, normally less.

## 18 CHECK LIST

The following points must be taken into account when installing and configuring a radio modem:

1. All operating voltages of all the equipment concerned must always be switched OFF before connecting the serial interface cable.
2. When considering the exact placement of a radio modem and/or its antenna, the following points must be taken into account to guarantee optimal results:
  - The antenna should be installed in open space as far as possible from any possible sources of interference
  - The radio modem should not be installed onto a strongly vibrating surface
  - The radio modem should be installed in such a way as to minimise exposure to direct sunlight or excessive humidity.
3. To ensure reliable operation the voltage output of the power supply must be stable enough and the current capability of the power supply must be sufficient.
4. The antenna must be installed according to instructions.
5. Serial interface settings between the radio modem and the terminal unit must correspond to each other.
6. All radio modems in the same system must be configured using same settings (radio frequency, channel spacing and data field length).

## **19 ACCESSORIES**

SATEL provides a wide selection of accessories and solutions for SATELLINE radio modems.

- Antennas
- Serial data/Power cables and adapters
- RF-cables
- Filters and lightning protectors
- Power supplies
- Enclosures

Please visit [www.satel.com](http://www.satel.com)

## 20 APPENDIX A

ASCII CHARACTER TABLE															
D	H	A	D	H	A	D	H	A	D	H	A	D	H	A	
0	0	NUL	43	2B	+	86	56	V	129	81		172	AC		
1	1	SOH	44	2C	,	87	57	W	130	82		173	AD	216	D8
2	2	STX	45	2D	-	88	58	X	131	83		174	AE	217	D9
3	3	ETX	46	2E	.	89	59	Y	132	84		175	AF	218	DA
4	4	EOT	47	2F	/	90	5A	Z	133	85		176	B0	219	DB
5	5	ENQ	48	30	0	91	5B	[	134	86		177	B1	220	DC
6	6	ACK	49	31	1	92	5C	\	135	87		178	B2	221	DD
7	7	BEL	50	32	2	93	5D	]	136	88		179	B3	222	DE
8	8	BS	51	33	3	94	5E	^	137	89		180	B4	223	DF
9	9	HT	52	34	4	95	5F	_	138	8A		181	B5	224	E0
10	A	LF	53	35	5	96	60	`	139	8B		182	B6	225	E1
11	B	VT	54	36	6	97	61	a	140	8C		183	B7	226	E2
12	C	FF	55	37	7	98	62	b	141	8D		184	B8	227	E3
13	D	CR	56	38	8	99	63	c	142	8E		185	B9	228	E4
14	E	SO	57	39	9	100	64	d	143	8F		186	BA	229	E5
15	F	SI	58	3A	:	101	65	e	144	90		187	BB	230	E6
16	10	DLE	59	3B	;	102	66	f	145	91		188	BC	231	E7
17	11	DC1	60	3C	<	103	67	g	146	92		189	BD	232	E8
18	12	DC2	61	3D	=	104	68	h	147	93		190	BE	233	E9
19	13	DC3	62	3E	>	105	69	i	148	94		191	BF	234	EA
20	14	DC4	63	3F	?	106	6A	j	149	95		192	C0	235	EB
21	15	NAK	64	40	@	107	6B	k	150	96		193	C1	236	EC
22	16	SYN	65	41	A	108	6C	l	151	97		194	C2	237	ED
23	17	ETB	66	42	B	109	6D	m	152	98		195	C3	238	EE
24	18	CAN	67	43	C	110	6E	n	153	99		196	C4	239	EF
25	19	EM	68	44	D	111	6F	o	154	9A		197	C5	240	F0
26	1A	SUB	69	45	E	112	70	p	155	9B		198	C6	241	F1
27	1B	ESC	70	46	F	113	71	q	156	9C		199	C7	242	F2
28	1C	FS	71	47	G	114	72	r	157	9D		200	C8	243	F3
29	1D	GS	72	48	H	115	73	s	158	9E		201	C9	244	F4
30	1E	RS	73	49	I	116	74	t	159	9F		202	CA	245	F5
31	1F	US	74	4A	J	117	75	u	160	A0		203	CB	246	F6
32	20	SP	75	4B	K	118	76	v	161	A1		204	CC	247	F7
33	21	!	76	4C	L	119	77	w	162	A2		205	CD	248	F8
34	22	"	77	4D	M	120	78	x	163	A3		206	CE	249	F9
35	23	#	78	4E	N	121	79	y	164	A4		207	CF	250	FA
36	24	\$	79	4F	O	122	7A	z	165	A5		208	D0	251	FB
37	25	%	80	50	P	123	7B	{	166	A6		209	D1	252	FC
38	26	&	81	51	Q	124	7C		167	A7		210	D2	253	FD
39	27	'	82	52	R	125	7D	}	168	A8		211	D3	254	FE
40	28	(	83	53	S	126	7E	~	169	A9		212	D4	255	FF
41	29	)	84	54	T	127	7F		170	AA		213	D5		
42	2A	*	85	55	U	128	80		171	AB		214	D6		

## 21 APPENDIX B

### 21.1 Functional delays

Function	Delay (ms)
Wakeup time from STANDBY to ON (controlled by DTR line)	123 ms (CTS active)
Wakeup time from Power OFF to Power ON (=ready to receive)	123 ms typical
Wakeup time from SLEEP to modem ready (triggered by data on TD line)	40ms typical
Turnaround time of serial interface	0 ms
Received data to transmitted data wait time, if RX frequency differs from TX frequency (settling time after frequency change)	>20ms app. >40 ms recommended for compatibility to prior SATELLINE-3AS radio modems
SL-Ping response time from remote modem	222 ms modem-to-modem without repeaters

### 21.2 Transmission delays

The tables on the next page present the transmission delays vs. the size of the message to be transmitted. The values are in 10% margin.

The delays are measured from the end of transmission to the end of reception on the serial interface as shown below.

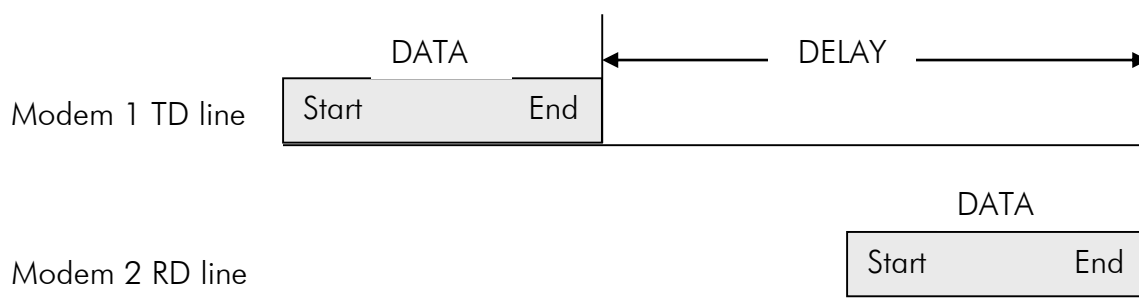

<b>SATELLINE-3AS mode (FEC OFF) on 12.5 kHz channel - Transfer delays</b>				
Bps	1 byte	10 bytes	100 bytes	500 bytes
1200	40 ms	40 ms	29 ms	22 ms
4800	34 ms	34 ms	31 ms	22 ms
9600	32 ms	32 ms	32 ms	27 ms
19200	32 ms	35 ms	64 ms	193 ms
38400	32 ms	36 ms	91 ms	352 ms

<b>SATELLINE-3AS mode (FEC ON) on 12.5 kHz channel - Transfer delays</b>				
Bps	1 byte	10 bytes	100 bytes	500 bytes
1200	52 ms	49 ms	48 ms	50 ms
4800	45 ms	45 ms	44 ms	44 ms
9600	44 ms	44 ms	68 ms	121 ms
19200	44 ms	44 ms	104 ms	360 ms
38400	48 ms	48 ms	132 ms	496 ms

<b>SATELLINE-3AS mode (FEC OFF) on 25 kHz channel - Transfer delays</b>				
Bps	1 byte	10 bytes	100 bytes	500 bytes
1200	30 ms	30 ms	18 ms	16 ms
4800	23 ms	23 ms	21 ms	12 ms
9600	23 ms	23 ms	21 ms	17 ms
19200	22 ms	22 ms	22 ms	19 ms
38400	22 ms	22 ms	38 ms	102 ms

<b>SATELLINE-3AS mode (FEC ON) on 25 kHz channel - Transfer delays</b>				
Bps	1 byte	10 bytes	100 bytes	500 bytes
1200	35 ms	34 ms	29 ms	30 ms
4800	28 ms	28ms	27 ms	23 ms
9600	28 ms	28 ms	28 ms	23 ms
19200	28 ms	28 ms	36 ms	64 ms
38400	27 ms	27 ms	58 ms	185 ms